

Preface

NOTES

This manual contains instructions on the installation, use, operation and other aspects of the UPS. Please carefully read this manual before installing the system. Do not operate the UPS before reading all the safety and operating instructions. This manual contains important information. Please strictly follow all warnings and operating instructions in this manual and on the machine and keep this manual properly.

SAFETY

The uninterruptible power supply must be reliably grounded before use.

Batteries must be replaced by qualified maintenance personnel. The law states that batteries of no use value are toxic wastes. Therefore, the waste batteries should be classified and recycled according to the requirements of the law on the prevention and control of environmental pollution.

WARNINGS

This product is only sold to partners who have a basic understanding of this product. To prevent accidents, you need to understand other installation requirements or measures.

The statements on this product in this document are for information purposes only and do not constitute any offer or acceptance.

The product design is subject to changes without prior notice. All pictures in this document are for reference only.

TABLE OF CONTENTS

CHAPTER ONE: SAFETY INSTRUCTIONS AND PRECAUTIONS	4
CHAPTER TWO: INTRODUCTION OF PRODUCT	5
2.1 PRODUCT INTRODUCTION.....	5
2.2 RUNNING MODES.....	7
2.3 FEATURES OF THIS SERIES PRODUCTS.....	10
CHAPTER THREE: INSTALLATION OF UPS SYSTEM.....	19
3.1 SITE SELECTION	19
3.2 INITIAL INSPECTION AND UNPACKING OF THE UPS	22
3.3 POSITIONING AND INSTALLATION.....	23
3.4 INTRODUCTION TO OPTIONS	30
3.5 POWER CABLE	32
3.6 EXTERNAL PROTECTIVE DEVICE.....	33
3.7 CONNECTION TERMINAL	34
3.8 WIRING	37
3.9 CONTROL CABLE AND COMMUNICATION.....	40
3.10 MAINTENANCE SOCKET.....	44
CHAPTER FOUR: OPERATION MANUAL	45
4.1 THE FIRST STARTING THE UPS	45
4.2 START UP STEPS (ENTER THE INVERTER POWER SUPPLY MODE).....	46
4.3 SHUTDOWN STEPS (COMPLETELY CLOSE THE UPS AND LOADS).....	47
4.4 TURNING ON AND OFF THE ECO MODE	48
4.5 OPERATION STEPS OF MAINTENANCE BYPASS	48
4.6 BATTERY COLD START STEPS (OPTIONAL).....	50
4.7 BRAKE UNIT SYSTEM (OPTIONAL)	51
4.8 MANUAL BATTERY MAINTENANCE.....	51
4.9 EMERGENCY POWER OFF (EPO) STEPS	52
4.10 STEPS OF TURNING ON/OFF PARALLEL MACHINE	52
4.11 RESET OPERATION AFTER FAILURE ALARM	55
4.12 AUTOSTART	55
4.13 SELECT LANGUAGES	55
4.14 CHANGE CURRENT DATE AND TIME.....	56

4.15	CONTROL PASSWORD	56
CHAPTER FIVE: OPERATION CONTROL DISPLAY PANEL.....		57
5.1	INTRODUCTION TO THE MONITORING PANEL	57
5.2	LIST OF EVENTS DISPLAYED ON LCD PANEL	66
CHAPTER SIX: DAILY MANAGEMENT AND MAINTENANCE		69
6.1	MACHINE ROOM MANAGEMENT	69
6.2	MAINTENANCE GUIDELINE	69
6.3	SAFETY PRECAUTIONS.....	69
6.4	PREVENTIVE PERIODIC MAINTENANCE	70
6.5	USE AND MAINTENANCE OF BATTERIES.....	70
6.6	SOFTWARE DOWNLOAD & INSTALLATION	71

Chapter One: Safety Instructions and Precautions



NOTE: Before operating this product, please carefully read all contents of this manual to avoid personal injury or equipment damage caused by misoperation.

1. This product is suitable to industrial, commercial, financial, transport and other situations, but cannot be used in situations where personal safety is directly endangered, such as the life support system.
2. Important systems of public safety or major economic interests must power the loads by Class A or Class B power supply architecture stipulated by GB50174, namely the double power supply system.
3. The external battery switch can be closed only when the inverter is running normally, or the internal components and batteries of the UPS may be seriously damaged, unless there is a battery cold start option between batteries and the UPS.
4. The UPS output terminal is still powered on when the mains supply fails. According to the requirements of EN 50091-1, the installer must identify the UPS-powered wires or plugs and inform the user.
5. Batteries of the complete series UPS are external devices. We recommend that batteries are installed when they can be charged by the UPS. If the batteries are not charged in a period of more than 2-3 months, irreparable damages will be caused to the batteries.
6. An industrial-grade fan is used in the UPS cooling system for forced air cooling, so the vent hole (air grid) should not be blocked.
7. When exiting from the maintenance mode, you must set the manual bypass to “ON” before closing the output switch, so as to avoid short circuits of the two-way power supply which may cause damage to the UPS.
8. The parts with yellow labels inside the machine are inaccessible to users to avoid electric shock.
9. After the machine is powered off, the maintenance socket may still have the mains supply. Please carefully check whether the external power switch of the UPS is disconnected to avoid electric shock.
10. The equipped USB cable is the communication line for RS232.
11. When the UPS is not in use (especially when the UPS is not in use for a long time), please disconnect the external battery switch to avoid the deep discharge of the battery which may cause irreparable damage to the battery.
12. When the bypass power supply fluctuates greatly, please power the load by the ECO mode of the UPS with caution, and the load may be powered down (the maximum power-down time is 10 ms).
13. The machine must be grounded before being powered on or operated to avoid personal injury caused by the leak current.
14. Before installation or maintenance, all power supplies must be disconnected, and the bus capacitance must be discharged (discharge time ≥ 15 min) before operating inside the machine.
15. The bold fonts with “

~ 4 ~

Chapter Two: Introduction of Product

2.1 Product introduction

This series product (10-500kVA) is a high-performance and fully digital Uninterruptible Power Supply (UPS) using the DSP control technology; the complete series UPS adopts the advanced rectifier and inverter control technology, and its performance indicators have reached the leading level in the industry. This series UPS is used to connect the mains supply and the important load to provide high-quality power supply for the load. It adopts high-frequency double-conversion pulse width modulation (PWM) and full digital control (DSP) technology, and the output voltage is not affected by the mains input voltage, frequency change and interference.

As shown in Fig. 2-1, the AC mains supply is input by the rectifier switch, and, after being converted to the DC power supply, charges the battery at all times via the battery switch. It also supplies power to the inverter, and the inverter converts the DC power supply into the pure AC power supply that is not disturbed by the mains supply. When the mains supply is interrupted, the battery provides the backup power to the load via the inverter. When the inverter fails or is overloaded and overtime, the load can also be powered by the bypass switch and bypass static switch. In addition, if the UPS needs to be maintained or repaired, the UPS can power the load through the manual control maintenance switch. When the UPS is running normally, all switches except the maintenance switch are closed.

Note: The power range of this series UPS is 10-500kVA. The DC input voltage of this series (10-120kVA) UPS is 360VDC, this series (80-500kVA) UPS is 600VDC. There are two types of this series (80-120kVA) UPS, for which the battery input voltages are 360VDC and 600VDC, and the sizes and weights are different. Users can choose the products according to their needs.

Battery switches and batteries of the complete series UPS are external devices. The 10-300kVA maintenance switches are built-in standard accessories, and the 400-500kVA maintenance switches are external optional accessories.

2.1.1 Separated bypass input

Fig. 2-1 shows the schematic diagram of the stand-alone this series UPS with “separated bypass power supply” (the bypass adopts independent mains input). In the separated bypass configuration, the static bypass and the maintenance bypass share a separate bypass power supply, which is connected to a dedicated bypass power supply via a separate power switch. If no separate bypass power supply is available, the bypass should be short-connected to the terminal of the rectifier input power supply.

When the complete series products leave the factory, the mains input and bypass input have been

separated. When the main input and bypass input need a common mains input, the UPS (10-120kVA, 200-300kVA) are connected by the equipped short connection line; the UPS (160kVA) is connected by the equipped copper bar, and the switch baffle needs to be removed before installation; the UPS (400-500kVA) is not equipped with wires or copper bars, and the user needs to configure them or purchase the corresponding optional accessories by themselves.

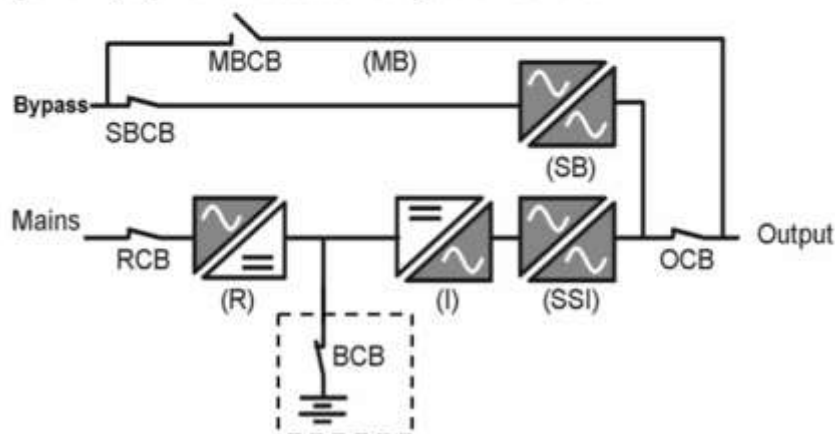

Fig. 2-1: Schematic diagram of the standard-alone system

2.1.2 Rectifier

The rectifier of This series UPS converts the three-phase voltage of the mains supply into the continuous DC voltage by fully digitally controlled three-phase rectification technology.

2.1.3 Inverter

The inverter of This series UPS converts the continuous voltage from the rectifier or battery into the AC voltage with a stable amplitude and frequency by the mature three-phase IGBT inverter technology. With the high-speed digital control technology, the distortion rate of sine waves generated by the inverter becomes low, and only small distortion is generated even there is a very high peak current on the load.

2.1.4 Static transfer switch

The “static switch” (Fig. 2-1) uses a controlled silicon as a conversion device for switching between the inverter power supply and mains power supply for the load. Under normal running conditions, the inverter output must be completely synchronized with the static bypass power supply, so that the inverter and the static bypass power supply can be switched without interruption. The synchronization between the inverter output and the static bypass power supply is achieved by the inverter control circuit. When the frequency of the static bypass power supply is in the allowable synchronization range, the inverter control circuit always causes the frequency of the inverter output to track that of the static bypass power supply.

In addition, the UPS also provides the manual control maintenance bypass. When the UPS needs to be turned off for daily maintenance and repairs, the UPS can supply the power to the important load

through the maintenance bypass.

2.1.5 Redundancy control electric power board

This series (160-500kVA) UPS is equipped with two identical auxiliary power supply boards, each being a standby to another. The two power supply boards get the input power supply from AC and DC sources. When one power supply or one auxiliary power supply board is faulty, the UPS system can still be running normally. This function provides higher reliability for the system.

2.1.6 Battery

The battery is installed in the external battery cabinet. The charge and discharge control function of the battery is fully integrated to the main control board. According to the DIN41773 standard, the battery needs to be charged after each partial discharge or full discharge. After fully charged, the battery continues to be floating charged to compensate for the self-discharge loss of the battery.

2.2 Running modes

This series UPS is an on-line, double-conversion UPS system, which has the following running modes:

- Mains and inverter power supply mode
- Battery mode
- Bypass mode
- Maintenance mode
- Economic (ECO) mode
- Parallel redundancy mode

2.2.1 Mains inverter power supply mode

The mains supply provides the AC power supply to the rectifier of the UPS through the main circuit input port, and the rectifier converts the AC power supply to the DC power supply. The AC power supply converted by the rectifier provides the charge power for the battery and also the input power for the inverter, and the inverter converts the DC power supply to the continuous interruptible AC power supply.

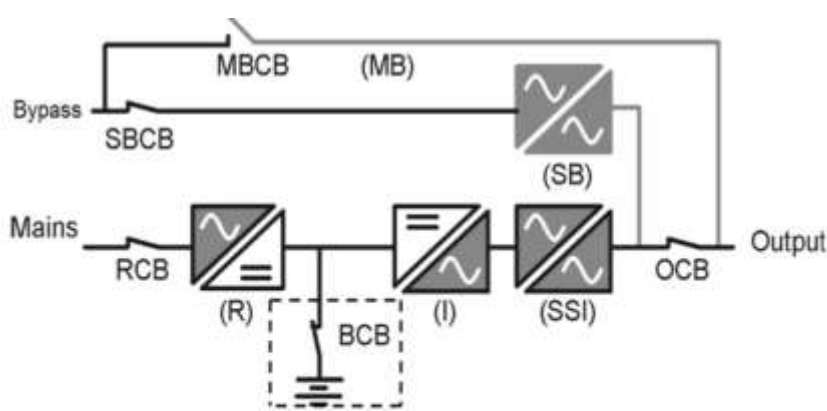

Fig. 2-2: Mains inverter power supply mode

2.2.2 Battery mode

The battery mode is a running mode where the battery provides the backup power to the load by inverter. When the mains supply is interrupted, the system automatically switches to the battery mode, and is powered by the battery and lasts until the scheduled backup time. The load is powered by the inverter output via the static switch, and the power supply is uninterrupted. After the mains supply is restored, the system automatically switches to the mains inverter power supply mode without any manual intervention, and the power supply is uninterrupted. If the backup time of the battery is up and yet the mains supply is not restored, the system will automatically switch to the bypass mode without interruption.

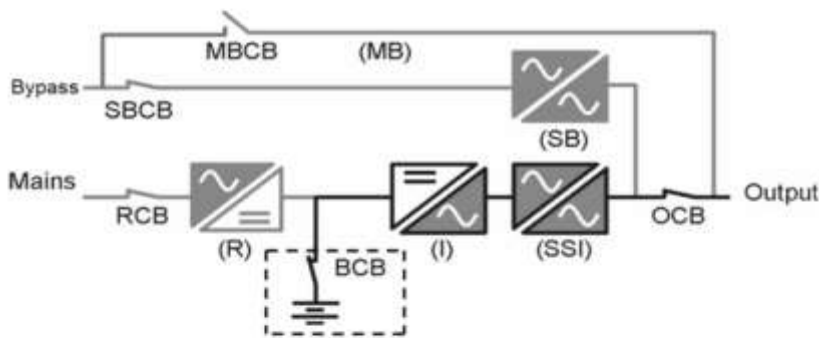

Fig. 2-3 Battery mode

2.2.3 Bypass mode

In the inverter power supply mode, if the inverter is faulty, the overload time of the inverter is up or the system is manually switched to the bypass mode, the load is switched from being powered by inverter to being powered by static bypass power supply by static switch, and the power supply of the load is uninterrupted. If the inverter is out of synchronization with the bypass at this time, the UPS turns off the inverter and inverter static switch and turns on the bypass static switch, and the power supply of the load is uninterrupted.



Note: when the UPS is running in the bypass mode, if the voltage and frequency fluctuate or the power supply is interrupted, the load will not be protected by the UPS.

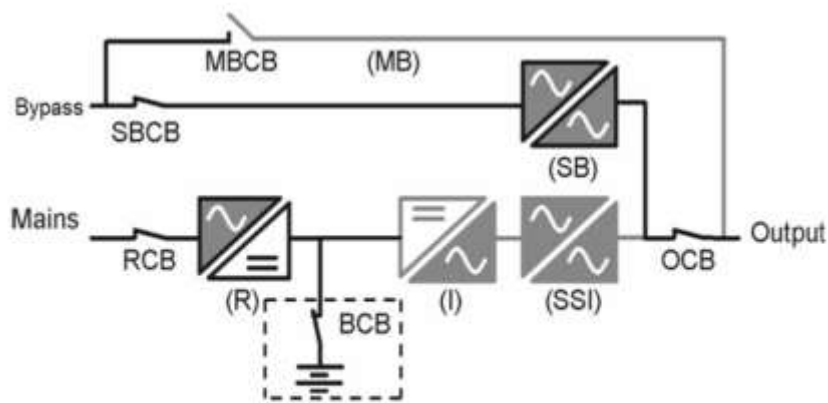

Fig. 2-4 Bypass mode

2.2.4 Maintenance mode

If daily maintenance or repair of the UPS is required, the load can be switched to the maintenance bypass via the maintenance switch, and the power supply of the load is uninterrupted. The maintenance switch of the UPS (10-300kVA) is a built-in standard accessory, and that of the UPS (400-500kVA) is an external option and can be flexibly configured with the external power distribution.

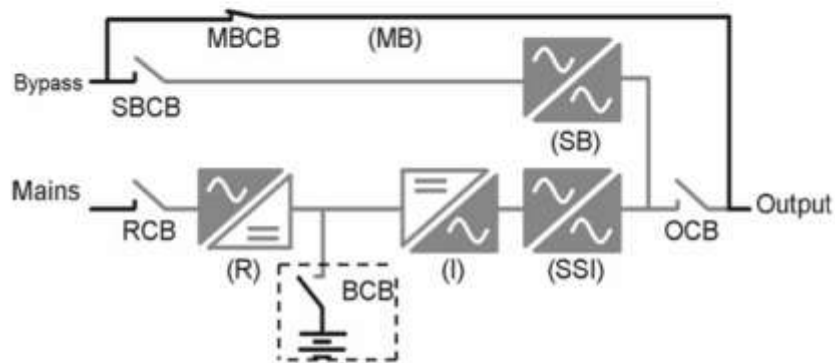

Fig. 2-5 Maintenance bypass mode

2.2.5 Parallel redundancy mode (system expansion)

To improve the capacity and reliability of the system, several stand-alone UPS can be directly connected in parallel and the parallel control system of each UPS ensures that all stand-alone machines automatically share the load.

If one machine in the parallel system fails, the machine will stop working and other normal machines continue to share the load. If all machines in the parallel system fail, the system will switch to the bypass mode. The parallel system consists of up to six stand-alone machines.

2.2.6 Economic (ECO) mode (only for the stand-alone system)

In the economic mode, the power supply of the load is preferentially supplied by bypass when the bypass power supply is normal, and the double-conversion UPS is in a standby state, so as to conserve the energy. When the bypass power supply is within the ECO working range, the power supply of the load is

supplied by bypass; when it is beyond the range, the system automatically switches to the inverter output, but the power supply of the load may be interrupted, with a maximum interruption time of 10ms. The mode cannot be used for loads or systems with strict requirements on switching time.

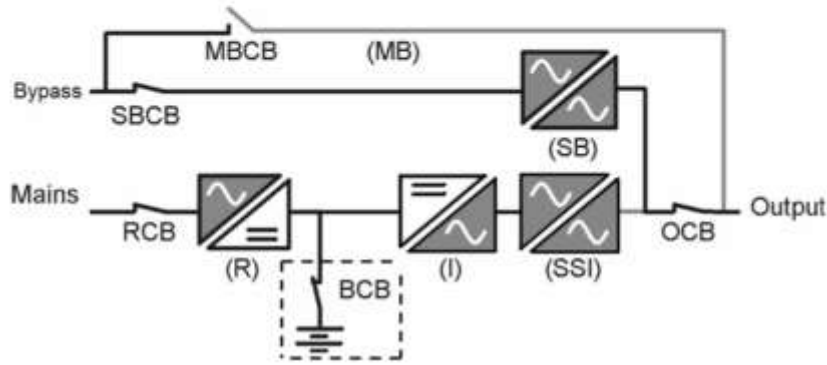

Fig. 2-6 ECO mode

2.3 Features of this series products

2.3.1 Performance features of this series UPS

- Three-phase input and output, supporting the 380/400/415V, 50/60Hz grid system
- Pure online double-conversion mode, providing the optimal power supply quality
- Strong capacity of carrying mixed loads, and have high overloading capacity
- The battery is directly connected to the bus, with good impact resistance of the output
- Unique ventilation design, the complete machine is of compact structure and small volume
- Coils of the output isolation transformer are winded by the DZn0 method of Δ/Y or Y/Y , with strong capacity of carrying unbalanced loads
- The input and output are fully isolated, and there is no serial-in DC in the load, with high safety
- The DSP is fully digitally controlled, realizing the full digitalization of rectifiers and inverters
- Self-diagnostic function, complete fault protection function, and 10,000 historical records can be inquired
- Class modular design, and the field maintenance is convenient and efficient
- Ultra-long mean time between failure (MTBF) (> 200,000 h)
- Short mean time between overhauls (MTTR) (< 0.5 h)
- Extra-large LCD interface display, touch operation mode, and friendly man-machine interface
- Options: battery cold start (standard for some models), SNMP card, WIFI card, 4G card, battery undervoltage release (optional for some models), lightning protector, power distribution cabinet, maintenance bypass switch integrated cabinet (optional for the 400-500kVA UPS), parallel kit (the stand-alone machine is expanded to the parallel machine), battery temperature sensor (temperature compensation, which is effective only in the lead-acid battery mode), short-connected copper bar with

the same mains and bypass power supply (optional for the 400-500kVA UPS), and brake unit system (optional for the 10-500kVA UPS). Instructions of some options have been provided with the UPS, and they are not elaborated in this manual.

2.3.2 Product performance parameters

Product performance parameters, Table 2-1

Rated capacity* (1)		10~120kVA	80~500kVA
Main circuit input	Rated input voltage	Line voltage 380/400/415V	
	Input mode	Three-phase three-wire	
	Voltage range	285V-475V	304V-456V
	Frequency range	(50/60) ± 10Hz	(50/60) ± 5Hz
	Delay start	10 s (this can be set to 1-300)	
	Limited input current	1.25 (this can be set to 0.1-1.25)	1.1 (this can be set to 0.1-1.1)
Bypass input	Rated input voltage	Phase voltage 220/230/240V	
	Voltage range	The upper limit of the bypass can be set to 10%,15%,20%, 25%; the default value is 20% The lower limit of the bypass can be set to 10%,20%,30%,40%,50%, 60%; the default value is 20%	
	Input mode	Three-phase four-wire	
	Frequency range	(50/60) ±5Hz	
ECO input	Rated input voltage	Phase voltage 220/230/240V	
	Voltage range	The upper limit of ECO can be set to 5%,10%, 15%; the default value is 10% The lower limit of ECO can be set to 5%,10%, 15%; the default value is 10%	
	Frequency range	(50/60) ±2Hz	
Output	Rated output voltage	220/230/240V three-phase four-wire	
	Rated output voltage trimming	[-5V,5V]	
	Power factor	0.9	
	Frequency tracking range	(50/60) ± 3Hz (this can be set to ±5Hz)	
	Normal switching time	Mains supply↔ battery: 0 ms, bypass↔ inverter:0 ms	
Output	Inverter Overloading capacity	When load ≤ 105%, the UPS can work for a long time; When 105% < load ≤ 110%, the UPS switches to bypass output after 60 minutes; When 110% < load ≤ 125%, the UPS switches to bypass output after 10 minutes; When 125% < load ≤ 150%, the UPS switches to bypass output after 1 minute; When 150% < load ≤ 200%, the UPS switches to bypass output after 200 ms; When 200% < load, the inverter is shut down (powered off) after 100 ms and the UPS switches to bypass output;	
System	ECO interruption time	In the ECO mode, when the bypass is abnormal, the maximum output interruption time is 10 ms	
	Display	LCD+LED	
	EMI	IEC62040-2	
	EMS	IEC61000-4-2(ESD) IEC61000-4-3(RS)	

	IEC6100-4-4(EFT) IEC6100-4-5(Surge)	
Insulation resistance	>2MΩ (500VDC)	
Insulation strength	2820Vdc, the leak current is less than 1mA, the time is 1 min, and there is no flashover.	
Surge protection	Meet the requirements for the installation site of class IV stipulated by IEC60664-1; that is, the capacity of withstanding the 1.2/50us+8/20us mixed wave is at least 6kV/3kA	
Cells* (2)	12V, 30 cells by default (this can be set to 28-32) 3.2V, 120 cells by default (this can be set to 105-120)	12V, 50 cells by default (this can be set to 48-52) 3.2V, 192 cells by default (this can be set to 192-208)
Wiring mode* (3)	Lower incoming line	
Protection grade (IEC 60529)	IP20	
Color	Black (Other colors can be customized)	

*(1) The power range of this series UPS is 10-500kVA, of which the DC input voltage of the UPS (10-120kVA) is 360VDC and that of the UPS (80-500kVA) is 600VDC. There are two types of this series (80-120kVA) UPS, for which the battery input voltages are 360VDC and 600VDC, and the sizes and weights are different. Users can choose the products according to their needs. Details are shown in the product weight and size parameter table.

*(2) There are 31-32 (or 181-192)/51-52 (or 301-312) lead-acid batteries, and the equalizing charge voltage of the batteries is lower than 14.1V (or 2.35V). If there are requirements for the equalizing charge voltage in the battery specification, please consult the equipment manufacturer.

*(3) All products can be wired from the bottom, and some can also be wired from the side. Some products can also be wired from the top by using the incoming cabinet. For specific models, please consult the equipment manufacturer.

Weights and sizes of This series (10-120kVA) UPS (excluding batteries), Table 2-2

Rated capacity (kVA)	10	15	20	30	40	60	80	100	120
Size: W×D×H (mm)	400×800×1100					600× 700× 1500	700×800×1700		
Gross weight (kg)	200	207	217	252	302	480	620	660	720
Net weight (kg)	158	165	175	210	260	460	590	630	690

Weights and sizes of This series (80-500kVA) UPS (excluding batteries), Table 2-3

Rated capacity (kVA)	80	100	120	160	200	250	300	400	500
Size: W×D×H (mm)	800×800×1800			800× 860× 1700	1210×860×1950			2380×860 ×1950	

Gross weight (kg)	630	680	730	840	1200	1340	1420	2200	2410
Net weight (kg)	580	630	680	790	1135	1275	1355	2090	2300

2.3.3 Comprehensive monitoring

The monitoring content of This series UPS is intact and complete. On the operation display panel, you can control the operations of the UPS, and view all parameters, battery status, and event and warning information of the UPS.

1. Schematic diagram of the monitoring display unit panel

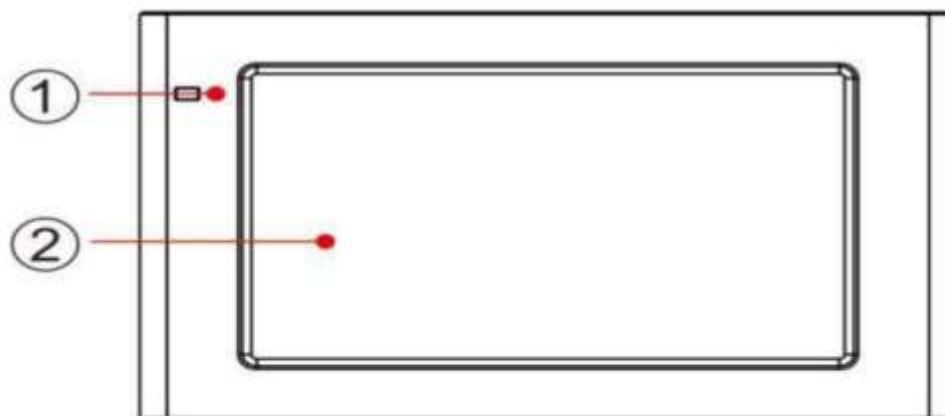

Fig. 2-7: Schematic diagram of the monitoring display unit panel

① LED indicator

② LCD display touch screen

The monitoring display unit displays the running information and warning information of the UPS in real time through the LCD, and can also set and manage parameters of the UPS through the LCD. The indicator status of the monitoring display unit is shown in Table 2-4 .

Table 2-4 Table of indicator status

Indicator	Color	Status	Meaning
Indicator	green	On	Power supply mode (mains mode, bypass mode, ECO mode, etc.)
	Red	On	UPS alarm
	Red	Flashing	UPS failure
	None	Off	Not started or standby mode

2. LCD display

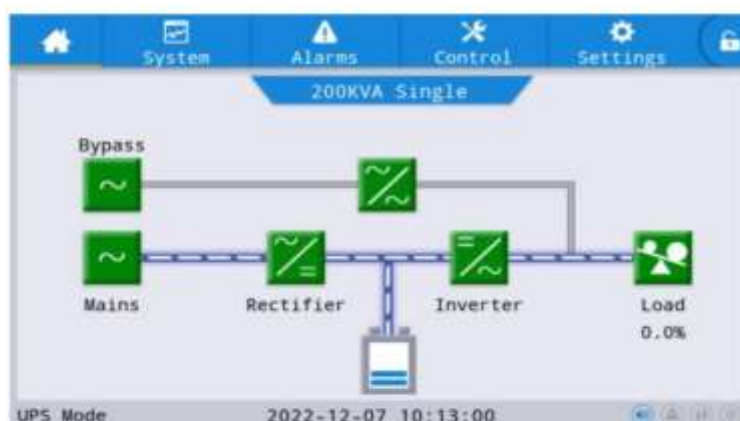

Fig. 2-8: LCD display

Table 2-5: LCD display

No.	Region	Functional description
1	Main menu	The first menu, including the main page, system, alarm, control, setting and password login, of which the control and setting menus are grayed before logging in the password.
2	Energy flow diagram	Display the energy flow state of the cabinet. Click the corresponding work interface to view the state information.
3	Status bar	Display the working status of the cabinet, system time, buzzer status, and alarm status

2.3.4 Perfect failure protection and warning

1. Warning information

In addition to the failure, UPS also sends the warning information to prompt the user when the following conditions occur.

Table 2-6: Warning prompts

Output overload	Bypass fault	EPO	BMS communication is abnormal (lithium battery only)
Abnormal communication	Batteries disconnected	Fan failure	

2. Failure protection

Whenever the failure occurs, the UPS will send an audible and visual alarm, and you can view the failure type and occurrence time in the history menu.

Table 2-7: Failure protection

Failure protection items	UPS action mode
A-phase output voltage is low	Turn off the rectifier, inverter and inverter static switches, and transfer to bypass output; after the fault is cleared, the UPS can exit from the failure mode and return to the normal working condition, and the load will not be powered down.
A-phase output voltage is high	
B-phase output voltage is low	
B-phase output voltage is high	
C-phase output voltage is low	
C-phase output voltage is high	
Bus overvoltage	
Battery low voltage	
Radiator over-temperature	
Input soft-start failed	
Rectifier failure	
Bus short circuit	
Fuse damaged	
Inverter over-temperature	
Inverter IGBT overcurrent	
Inverter soft start failed	
Inverter thyristor failure	
Charger failure	

Bypass thyristor failure	Shutdown (ECO mode, transfer to inverter output)
Bypass overload is delayed to	Shutdown
Output short circuit	Transfer to bypass
Mains supply failure	Do not turn on the rectifier
Bypass failure	Do not convert to bypass

2.3.5 Modular design and comprehensive front maintenance

In the structure design, we consider the operability of the field maintenance, and adopt the advanced front maintenance design concept to realize the class modular design inside the UPS by functions, and the product is easily installed and maintained. The following pictures only show the appearance of the product and do not contain the size information. Please refer to the material object.

1. This series (10-60kVA) model

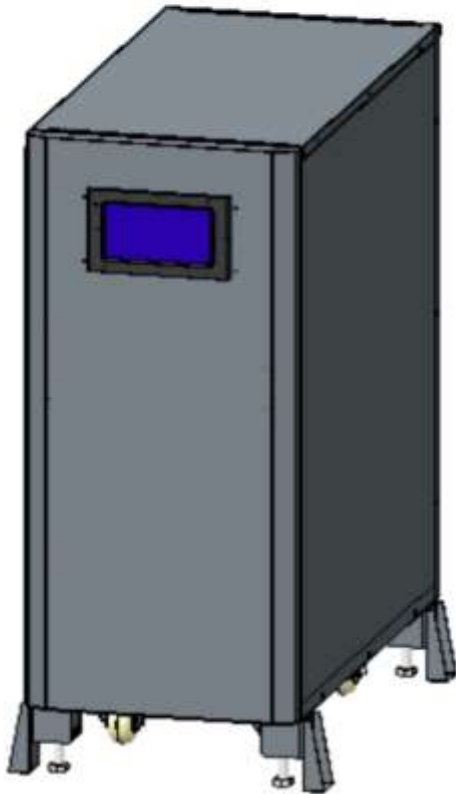

Fig. 2-9: This series (10-40kVA) model



Fig. 2-10: This series (60kVA) model

2. This series (80-120kVA) models



Fig. 2-11: This series (80-120kVA) models

3. This series (160-300kVA) model



Fig. 2-12: This series (160kVA) model

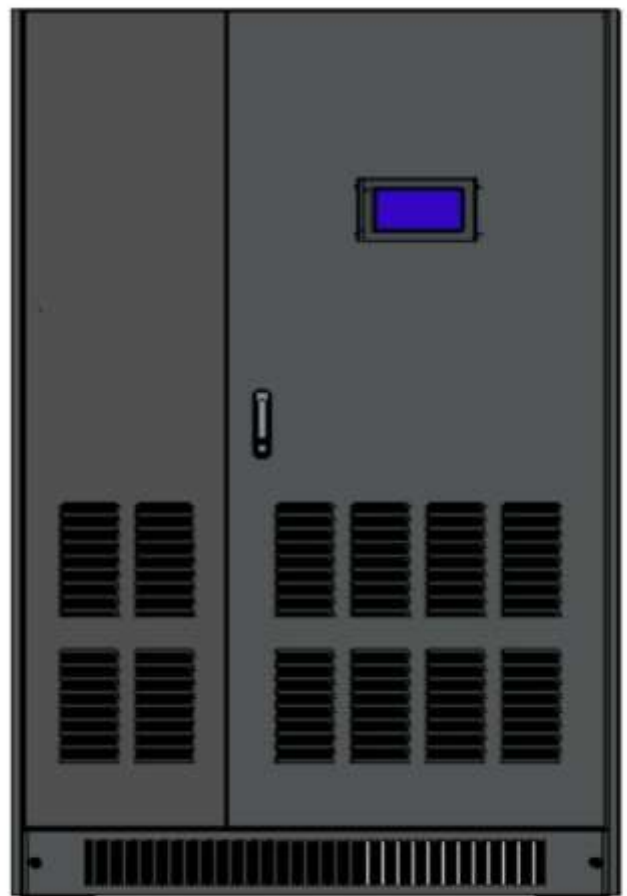

Fig. 2-13: This series (200-300kVA) model

4. This series (400-500kVA) model

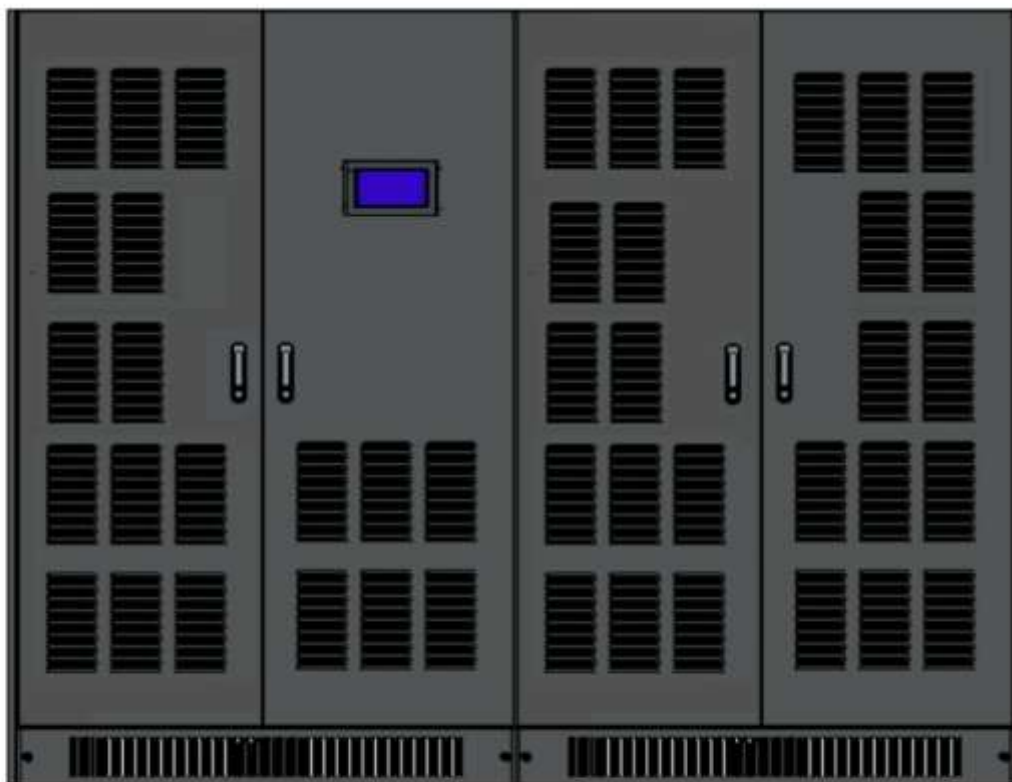

Fig. 2-14: This series (400-500kVA) model

2.3.6 Options

1. SNMP card, WIFI card, 4G card

We can remotely manage the UPS via the Internet and view the operating parameters and warning messages of the UPS.

2. Lightning protector

This is used to suppress the overvoltage in the power distribution caused by the lightning surge and protect the UPS or the backend load.

3. Parallel kit

When the stand-alone machine is expanded to the parallel machine, the parallel kit is needed.

4. Battery temperature sensor

This is mainly used to collect the working temperature of the external battery and realize the function of temperature compensation of the battery charging voltage.

5. Battery cold start option (some models are standard and some are optional)

The machine is powered on by the battery directly when there is no AC input.

6. Battery undervoltage release (suitable for ABB T4-T6 moulded case circuit breaker)

In the case of machine failure or battery low voltage, this option can automatically disconnect the battery switch to prevent the irreparable damage caused by the deep discharge of the battery. When the battery switch contains an undervoltage release, the battery switch can be closed only when the inverter is

working normally, and forcefully closing the battery switch may cause damage to the switch or the machine.

7. Power distribution cabinet (optional for the 80-500kVA UPS)

The upper incoming line pattern is provided. If the upper incoming cabinet is required for other models, please consult the UPS manufacturer.

8. Maintenance bypass switch integrated cabinet (optional for the 400-500kVA UPS)

This option contains the maintenance switch and battery switch, and has the upper incoming line function.

9. Short-connected copper bar with the same mains and bypass power supply (optional for the 400-500kVA UPS)

When there is only one mains input (mains input or bypass input), the mains input and the bypass input should be connected.

10. Brake unit options (optional for the 10-500kVA UPS)

This option absorbs the regenerated energy generated by the load to prevent the failure or damage of the UPS due to overvoltage. Such as elevators, textile machines, paper-making machinery, centrifuges, wire drawers, winding machines, proportional linkage systems, overhead cranes, conveyor belts, motors with positive and negative rotation function and other loads.

11. Battery switch box

The battery switch is optional for some products, and users can choose the battery switch box as required.

2.3.7 Configuration variance table

The configuration variance table for This series UPS is as follows

Table 2-8: Configuration variance table

Model	DC Voltage	Maintenance Switch	Battery Switch	Battery Cold start	Mains bypass connection fitting	Caster
This series (10-40kVA)	360VDC	✓	✓	✓	✓	✓
This series (60-120kVA)	360VDC	✓	×	✓	✓	×
This series (80-300kVA)	600VDC	✓	×	×	✓	×
This series (400-500kVA)	600VDC	×	×	×	×	×

Chapter Three: Installation of UPS System

This chapter describes the requirements for UPS site selection and cabling.

Since each site has its own particularities, this chapter does not describe the detailed installation steps and only provides general instructional installation steps and methods for the qualified installation personnel.

The installation personnel use these steps and methods according to the specific situation of the site.

- In electrical connection, the personnel should connect the ground wire of the UPS first, and disconnect all switches before the UPS is installed.
- The UPS should be installed by qualified engineers in accordance with this chapter as well as local regulations and standards. Other equipment not covered in this manual is shipped with detailed mechanical and electrical installation data.
- Battery installation requires special care. When connecting the battery, the voltage at the battery terminal exceeds 300VDC, which may be deadly. Please wear the eye shield to avoid damages of accidental arc to eyes. Remove all metal items such as rings and watches. Use tools with insulated handles. Wear rubber gloves. If the battery electrolyte leaks or the battery is damaged, the battery must be replaced, and the old battery must be placed in a container resistant to sulfuric acid, and is scraped according to local regulations. The skin should be rinsed immediately with water if it is exposed to the electrolyte.

3.1 Site selection

3.1.1 UPS room

The following requirements should be noted when selecting the UPS room:

1. The UPS must be installed in a room where the floor is smooth, clean and dry (relative humidity: 5%-90%), and kept away from pollution sources (such as seaside, conductive dust, metal mines, corrosive gases and liquids) and combustibles. If the UPS is near a pollution source, it must be placed in a dedicated machine room that meet the dust proof, moisture proof, corrosion proof and other basic requirements.
2. The UPS and batteries should not be installed directly below firefighting pipes, sewer pipes, air conditioning pipes and other pipes to prevent damages to the UPS and batteries caused by pipe leakage. If these conditions cannot be avoided, the UPS must be drop-proof.
3. The room temperature must be appropriate: the UPS can be operated in an indoor environment of 0-40°C, but the temperature must be higher than 0°C when turning on the UPS. The optimal operating temperature is 25°C. Users should ensure that the air in the room is fully convected, so that the equipment is fully cooled; if necessary, indoor exhaust fans should be installed to avoid the increase of the room temperature. The machine room precision air conditioning can also be selected. The equipment is not suitable outdoors. When the temperature in the machine room exceeds the operating temperature of

the UPS, the equipment should be derated. For details, please consult the manufacturer.

- Altitude: below 1,000 meters; the equipment used above the height should be derated. If the equipment is used above 3,000 meters, please consult the manufacturer.
- This series (10-300kVA) UPS is integrated in a cabinet, and the UPS (400-500kVA) is composed of a rectifier cabinet and an inverter cabinet, as shown in Fig. 3-4. The rectifier cabinet and the inverter cabinet are of the same size. Each cabinet must be handled separately and then connected in parallel together.

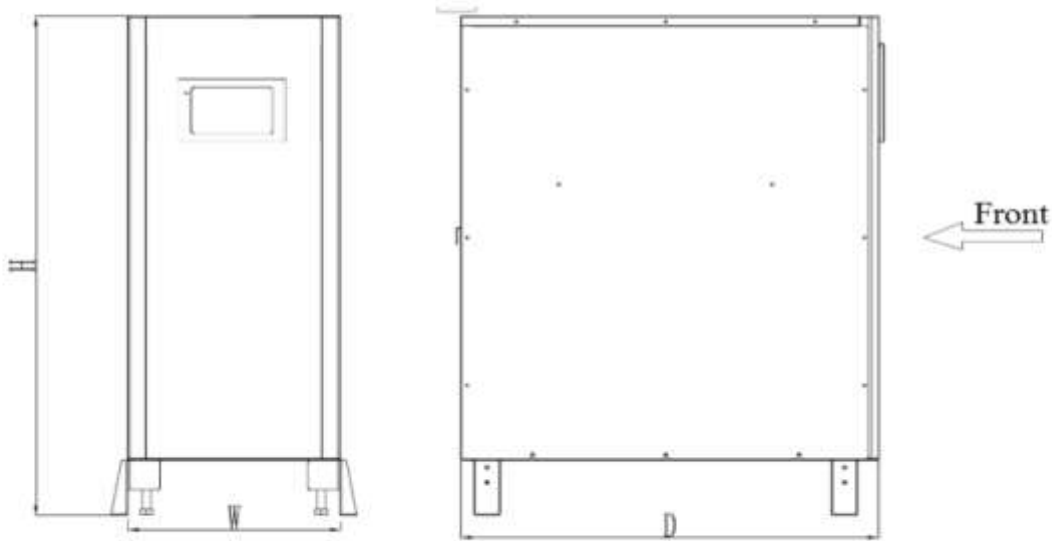

Fig. 3-1: External view of This series (10-40kVA) complete machine

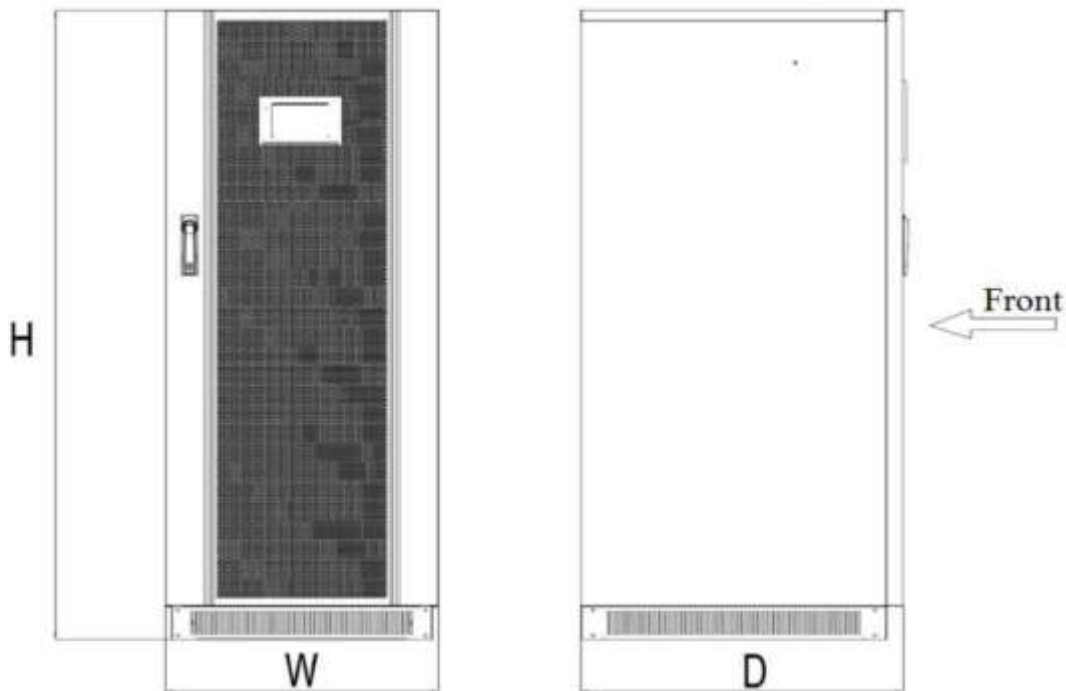

Fig. 3-2: External view of This series (60-160kVA) complete machine

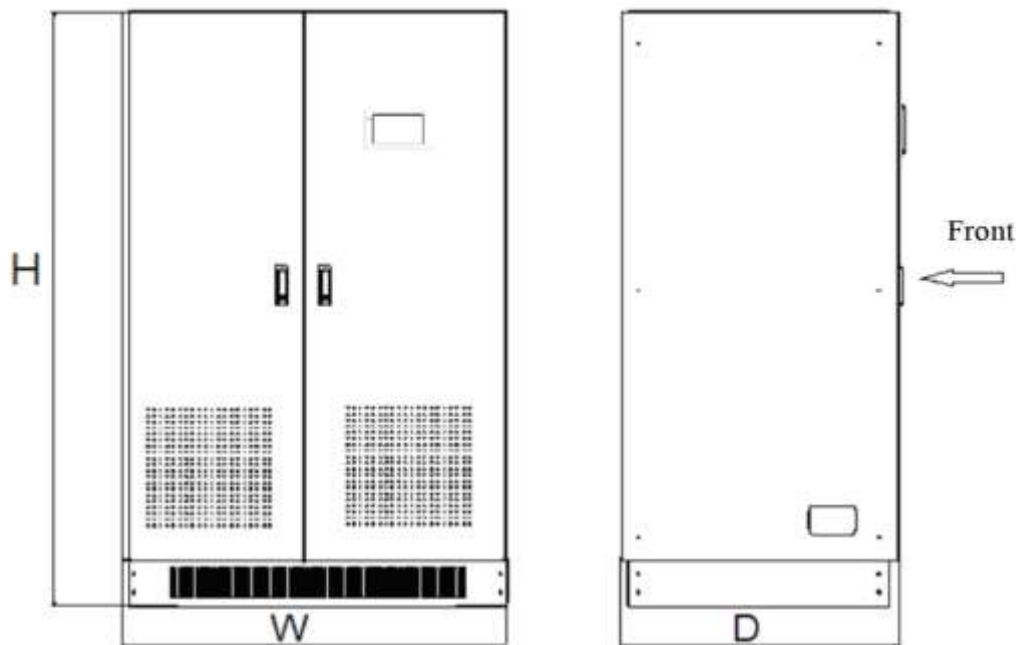

Fig. 3-3: External view of This series (200-300kVA) complete machine

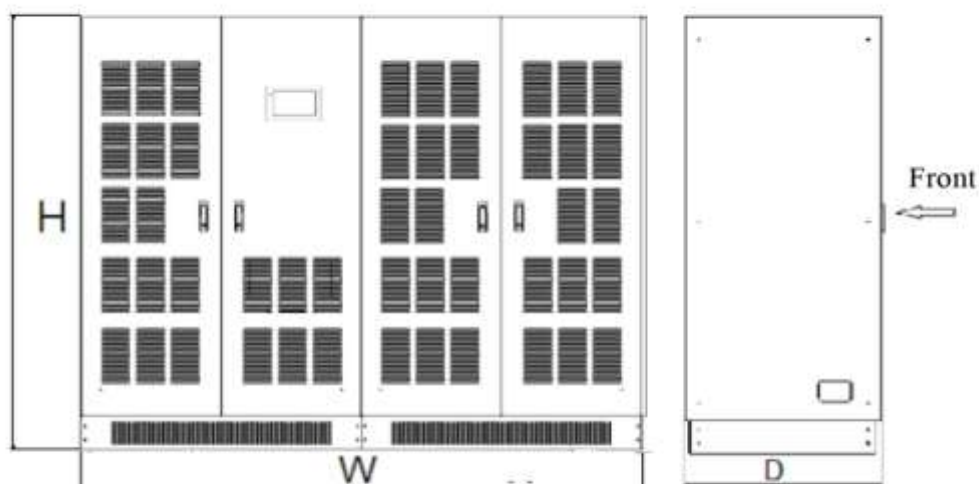

Fig. 3-4: External view of This series (400-500kVA) complete machine

3.1.2 External battery room

The environmental temperature for the batteries should be constant. The environmental temperature is the main factor affecting that battery capacity and life. The standard operating temperature for the battery is 20°C-25°C. Operating at an environmental temperature above the range will shorten the battery life, and operating at an environmental temperature below the range will reduce the battery capacity. In general, the allowed environmental temperature for the battery is 15°C-25°C. To avoid the formation of the explosive mixture of hydrogen and oxygen, the battery should be kept away from heat sources and properly ventilated (EN50091-1 annex N). The battery switch should be installed as close to the battery as possible, and the cabling distance between the battery and the UPS should be as short as possible.

3.1.3 Storage

If the UPS is not installed immediately, the equipment should be placed vertically according to the instructions on the package, and then the packing box should be stored in a dry, sheltered room to avoid dust and high temperature.

If the machine room or the place where the device is stored needs to be decorated or the UPS is not in use for a long time, the equipment must be covered with the package box to prevent dust or other impurities from entering the UPS case and affecting the reliability of the machine.

3.2 Initial inspection and unpacking of the UPS

During transportation, the cabinet is fixed on a wooden pallet using screws and is protected with packing materials.

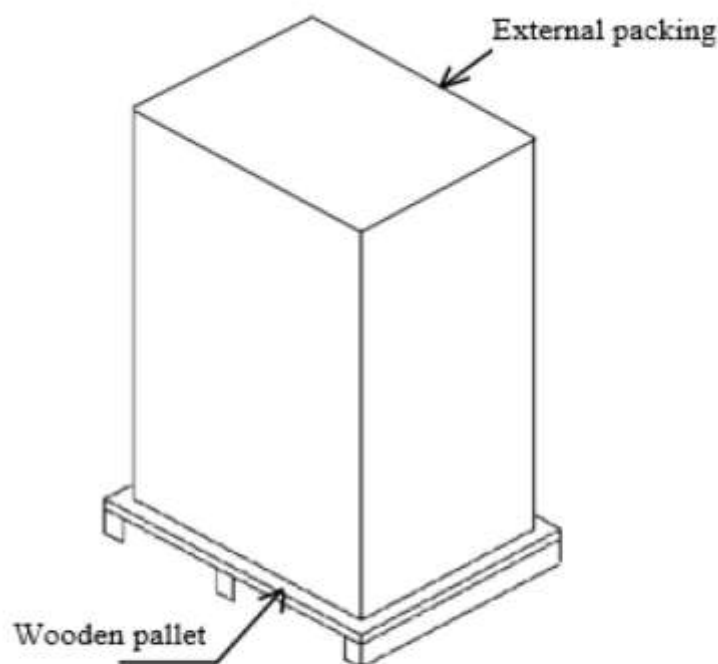

Fig. 3-5: External packing and wooden pallet of the UPS

The following operations should be performed before installing the UPS:

1. Carefully check the external packing to ensure that there is no obvious damage during handling; visually inspect whether the UPS and batteries are damaged during transportation after unpacking. In case of any damage, please inform the carrier immediately and contact the customer service personnel as soon as possible.
2. Unpack the box and remove the protective foam.
3. Check the technical data sheet of the product to ensure the correctness of the equipment. The technical data sheet of the UPS is on the label inside the front door. The label indicates the model, capacity and main parameters of the UPS.
4. Please remove the fixed screws first before removing the cabinet from the wooden pallet. Remove the

front board and back board at the bottom of the UPS cabinet to find the screws that fix the cabinet and the wooden pallet, as shown in Fig. 3-6 and Fig. 3-7;

5. Move the cabinet removed from the wooden pallet to the installation site using the forklift.

⚠ Note: since the machine is heavy, please keep the cabinet perpendicular to the ground during removal or transportation to avoid personal casualties or property damage caused by the collapse of the machine.

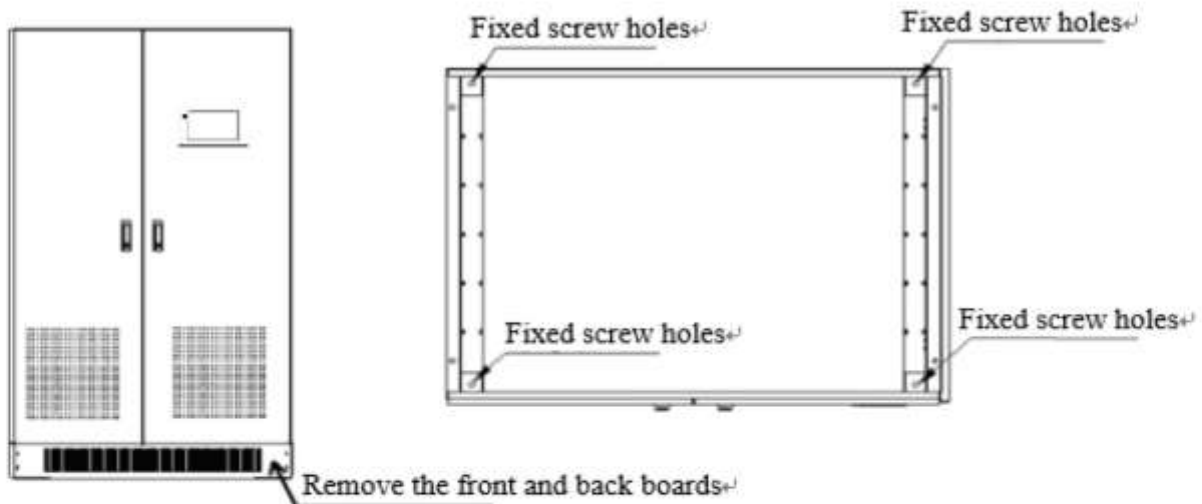

Fig. 3-6:Schematic diagram of board position Fig. 3-7:Schematic diagram of fixed screw holes on the cabinet and pallet

3.3 Positioning and installation

The component layout of the UPS allows the equipment to be maintained, diagnosed and repaired from the front and thus reduces the space requirements for the sides and the back. The power supply terminal, auxiliary terminal block and power supply operating switch are accessible after opening the front door of the UPS.

The selection of UPS position should ensure that:

- The line is connected conveniently;
- It has sufficient operating space;
- It is well ventilated to meet the cooling requirements;
- There is no corrosive gas around it;
- It is away from combustibles;
- There is no excessive moistening and high temperature sources;
- It is not dusty;
- It meets the fire fighting requirements;
- The optimal working environmental temperature is: $+20^{\circ}\text{C}$ - $+25^{\circ}\text{C}$, which is also the temperature range for the maximum battery efficiency.

3.3.1 Operating space

The air grids of This series (10-60kVA) UPS are on the front and back boards, and their distance from the wall should be kept at 1,000 mm; the air grids of This series (80-500kVA) UPS are on the front door and the roof, and the distance between the roof and the wall should also be kept at 1,000 mm to ensure the unobstructed exhaust of the UPS; the distance between the back of This series (400-500kVA) UPS and the wall should be at least 500mm to ensure that it can be conveniently connected to the cabinet in parallel. In addition to meeting local regulations, there should be enough space in the front of the UPS to the extent that people can freely pass through it when the front door of the UPS is completely opened. For convenience of daily maintenance, at least 500mm should be reserved at the back of This series (80-500kVA) UPS, and there should be at least 1,000 mm spacing between the top of the UPS and the ceiling to ensure the unobstructed exhaust at the top of the UPS.

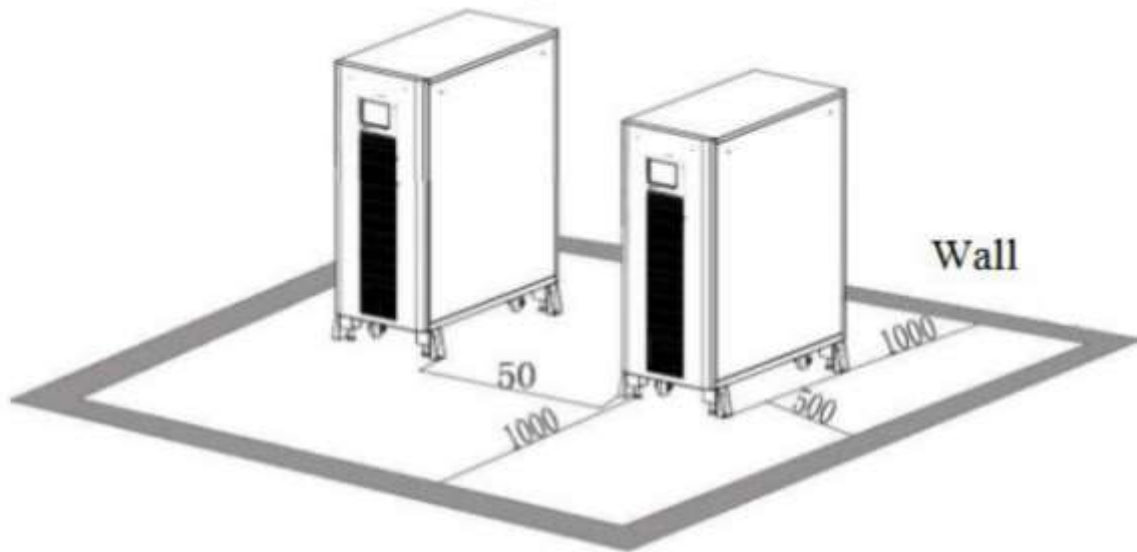

Fig. 3-8: Diagram of installation space of this series (10-40kVA) UPS (unit: mm)

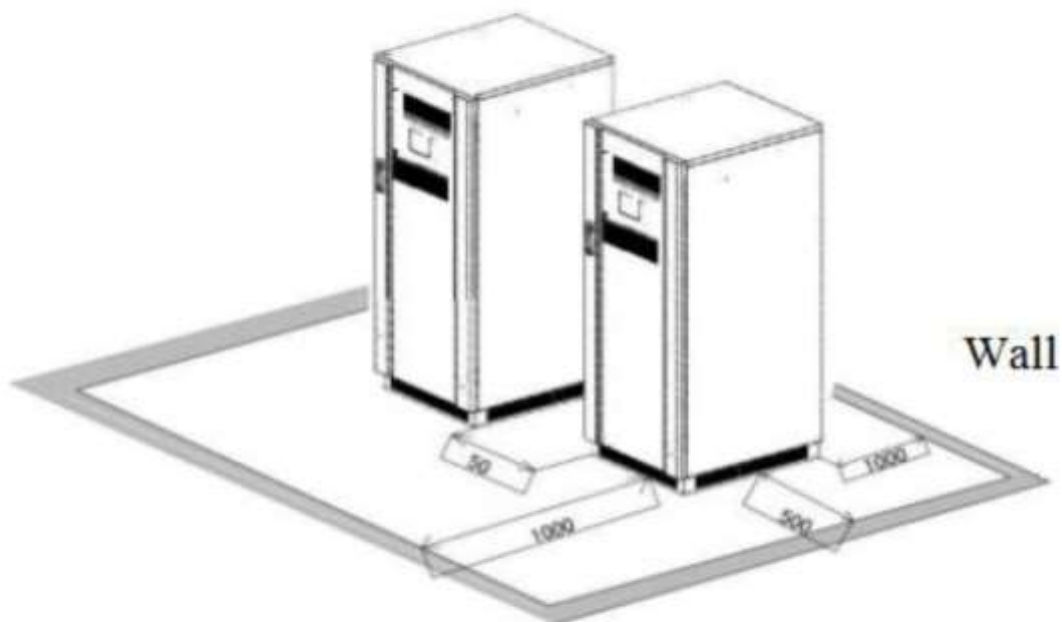

Fig. 3-9: Diagram of installation space of this series (60kVA) UPS (unit: mm)

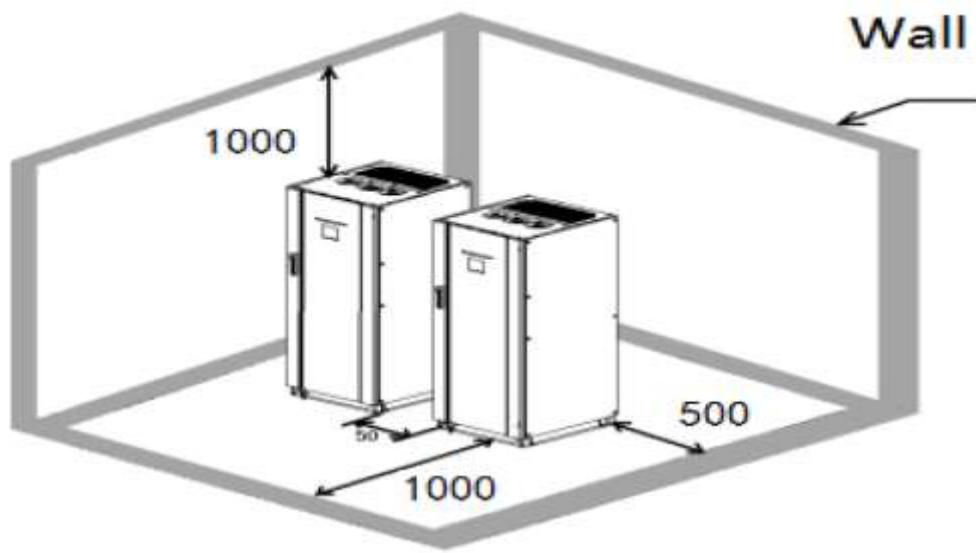

Fig. 3-10: Diagram of installation space of this series (80-160kVA) UPS (unit: mm)

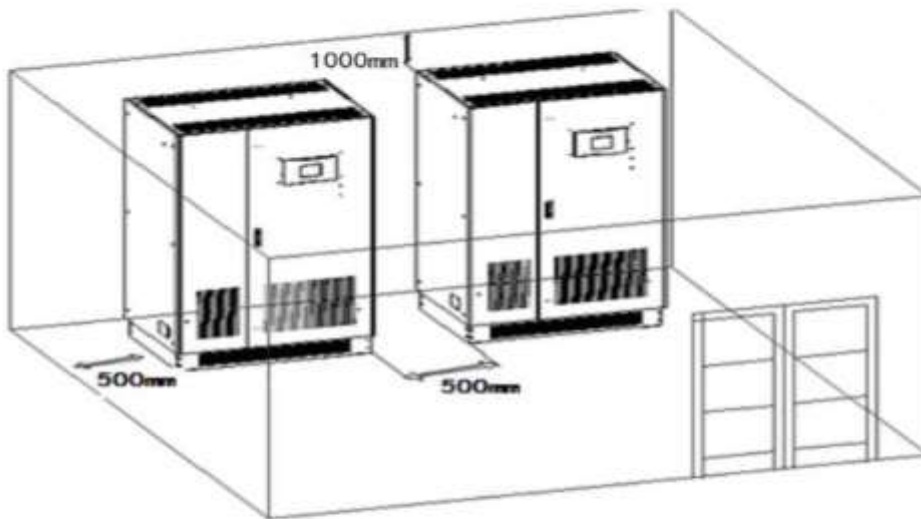

Fig. 3-11: Diagram of installation space of this series (200-300kVA) UPS (unit: mm)

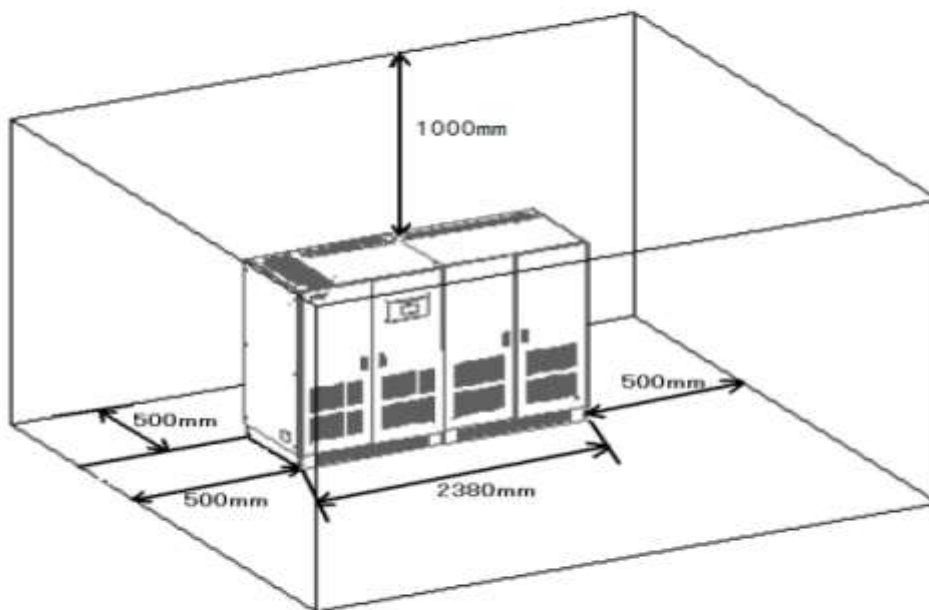

Fig. 3-12: Diagram of installation space of This series (400-500kVA) UPS (unit: mm)

3.3.2 Handling of cabinets

The lifting device for handling the UPS cabinet should have sufficient lifting capacity (the total weight of the UPS is shown in Table 2-2 and Table 2-3). When handling the machine, the rectifier cabinet and the inverter cabinet of this series (400-500kVA) UPS should be handled separately. Before being placed in the final position, the UPS can be lifted or handled using a pallet truck or forklift; the forklift can be pushed only after the front and lower board is removed.

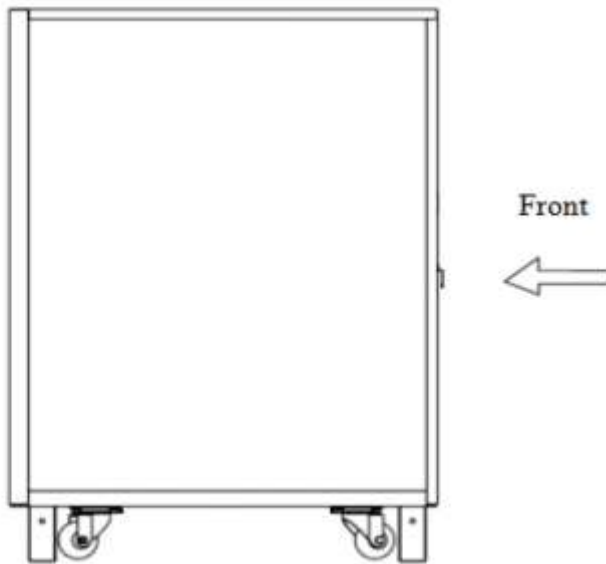

Fig. 3-13: Handling of this series (10-40kVA)

UPS (without casters) (unit: mm)

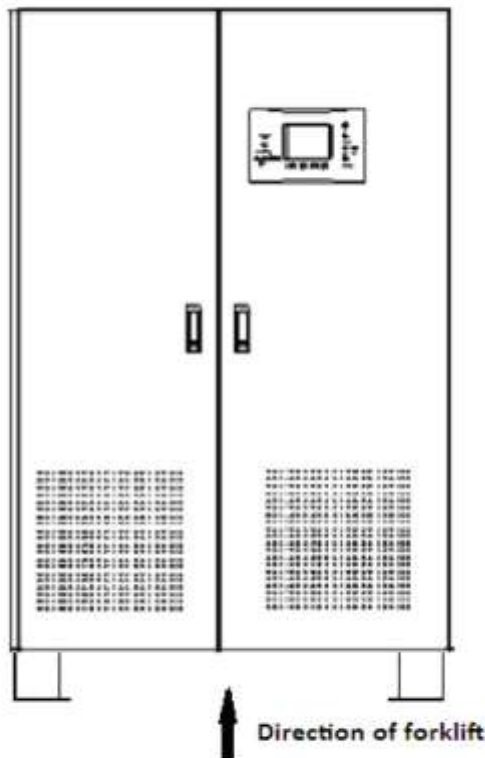

Fig. 3-15: Handling of stand-alone cabinets of this series (200-500kVA) UPS

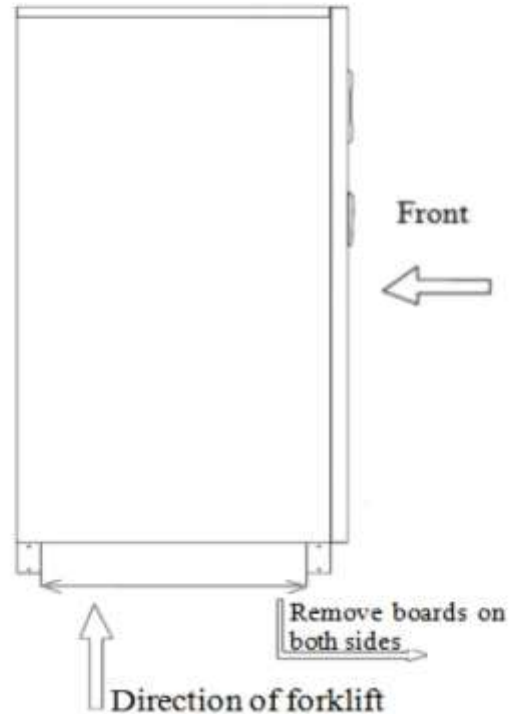
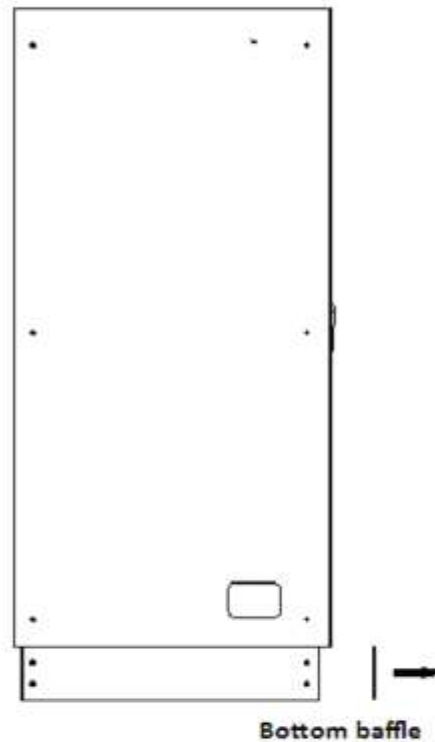

Fig. 3-14: Handling of this series (60-160kVA)

UPS (unit: mm)



3.3.3 Procedures of parallel installation of cabinets

Procedures of parallel installation of two cabinets of this series (400-500kVA) UPS are as follows:

1. Place in parallel. The rectifier cabinet and the inverter cabinet are placed in parallel, as shown in Fig. 3-16. When placing the cabinets, there should not be a gap between the two cabinets, and the front and back of the two cabinets should be kept at the same level.

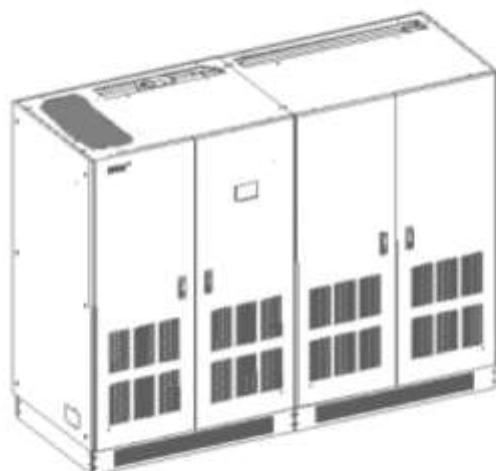

Fig. 3-16: View of parallel placement of the rectifier cabinet and the inverter cabinet of This series (400-500kVA) UPS

2. Fix the installation. Remove the back board of the machines placed in parallel, fix the two cabinets using screws at the “fixed holes on two cabinets connected in parallel” (as shown in Fig. 3-17), and then install the back board of the machines.

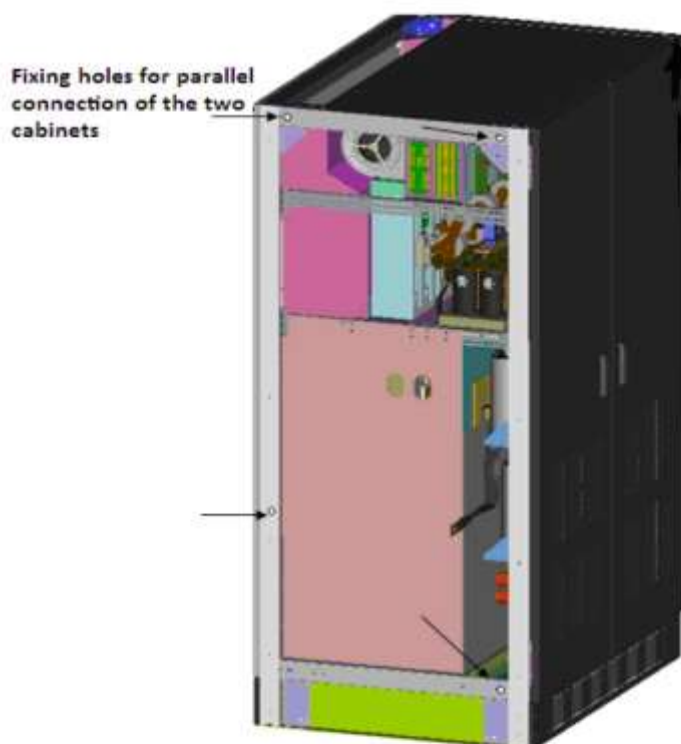

Fig. 3-17: Diagram of fixed holes on the rectifier cabinet and the inverter cabinet of This series (400-500kVA) UPS

3. Connect the bus. Connect the bus soft copper bar of the rectifier cabinet (as shown in Fig. 3-18) correspondingly to the bus copper bar of the inverter cabinet (as shown in Fig. 3-19).

⚠ Note: +BUS, N and -BUS must be connected correspondingly.

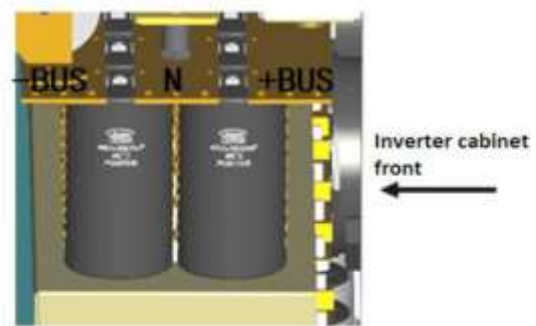
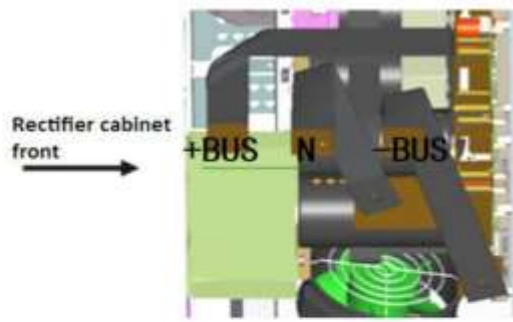

Fig. 3-18: Bus soft copper bar of the rectifier cabinet

Fig. 3-19: Bus copper bar of the inverter cabinet

4. Connect the conversion copper bars of the rectifier cabinet and the inverter cabinet. Connect the “inverter conversion terminal” of the rectifier cabinet to the “inverter output terminal” of the inverter cabinet using the soft copper bar provided with the machine. When connecting, the phase sequences should be connected correspondingly (for example: “A phase at the inverter conversion terminal” is correspondingly connected to “A phase at the inverter output terminal”). The null line (N) copper bar between the rectifier cabinet and the inverter cabinet should also be connected. As shown in Fig. 3-20.

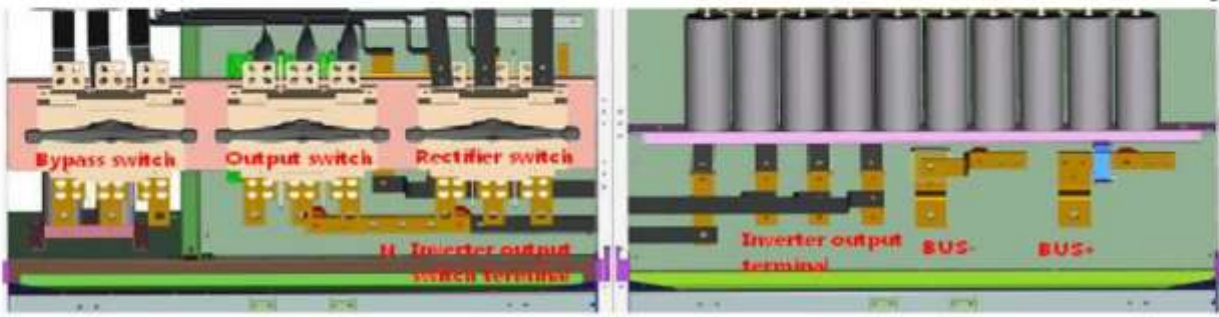

Fig. 3-20: View of inverter connection of This series (400-500kVA) UPS

5. Connect the signal line. An unconnected signal line on the upper right of the rectifier cabinet is connected correspondingly to the conversion board on the upper left of the inverter cabinet (as shown in Fig. 3-21). The connection between the signal line mark and the corresponding terminal is shown in Table 3-1.

Table 3-1: Corresponding connection of terminals

Conversion board one	Conversion board two
Line J2 is connected to the port of conversion board J2	Line J4A is connected to conversion board J4A
Line J4 is connected to the port of conversion board J4	Line J3B is connected to conversion board J3B
Line J5 is connected to the port of conversion board J5	Line J2B is connected to conversion board J2B
Line J8 is connected to the port of conversion board J8	Line J1B is connected to conversion board J1B

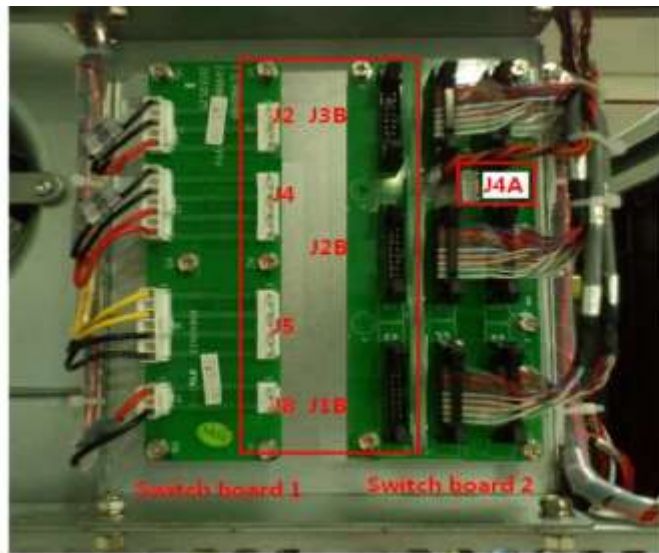

Fig. 3-21: Connection of signal lines of This series (400-500kVA) UPS

3.3.4 Incoming line patterns

This series UPS are wired from the bottom. When connecting the line, the terminal block for connecting power cables is seen after opening the front door of the UPS and removing the lower board (the board is at the lower back for the 10-40kVA UPS). The incoming channel of the UPS (60-500kVA) is seen after opening the front door and removing the board under the connection terminal. If you need the upper incoming line, please purchase the power distribution cabinet (optional for the 80-500kVA UPS) or the maintenance bypass switch cabinet (optional for the 400-500kVA UPS).



Fig. 3-22: Installation diagram of UPS and power distribution cabinet (which can be installed on the left)

3.4 Introduction to options

3.4.1 Power distribution cabinet and maintenance bypass switch cabinet

The power distribution cabinet can be used for this series (80-500kVA) UPS, and the maintenance bypass switch integrated cabinet can be used for this series (400-500kVA) UPS. The standard power distribution cabinet or maintenance bypass switch cabinet is integrated with the UPS, with the depth and height consistent with those of the UPS. During installation, we need to remove the side plate of the UPS, combine the power distribution cabinet or the maintenance bypass switch cabinet with the UPS, and install the screws. After the combination, we need to install the side plate of the UPS on the power distribution cabinet or the maintenance bypass switch cabinet.

The power distribution cabinet and maintenance bypass switch cabinet provide the upper incoming line and lower incoming line patterns, as shown in Fig. 3-23 and Fig. 3-24;

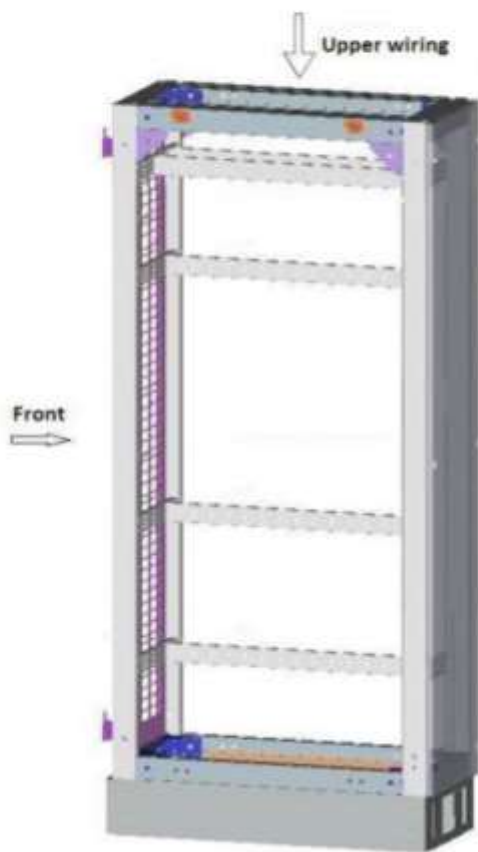

Fig. 3-23: Power distribution cabinet of this series (80-500kVA) UPS

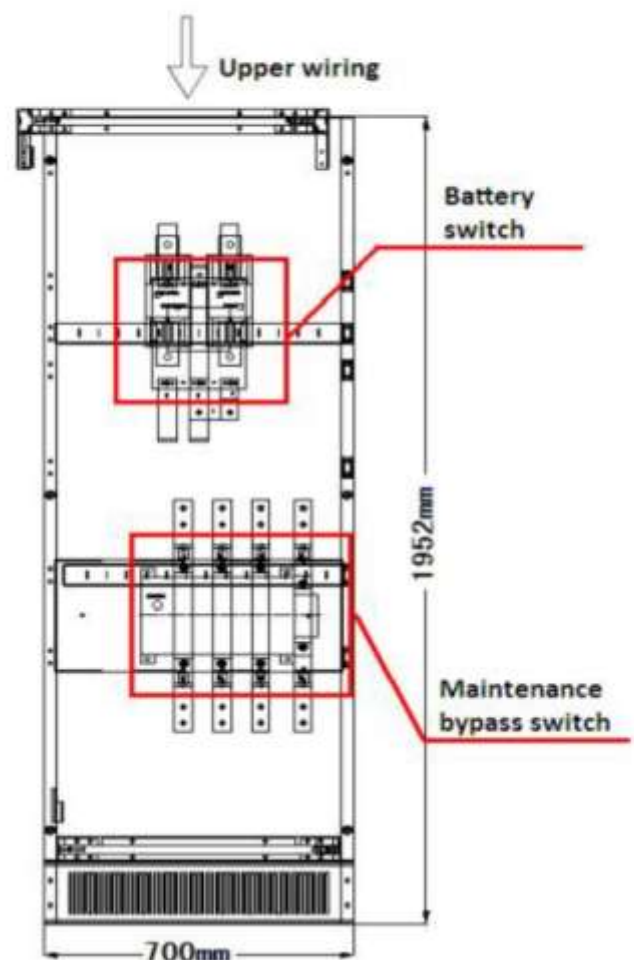

Fig. 3-24: Maintenance bypass switch integrated cabinet of this series(400-500kVA) UPS

3.4.2 Battery cold start (optional)

Battery cold start provides the function of powering on the UPS directly by batteries, as shown in Fig. 3-25;

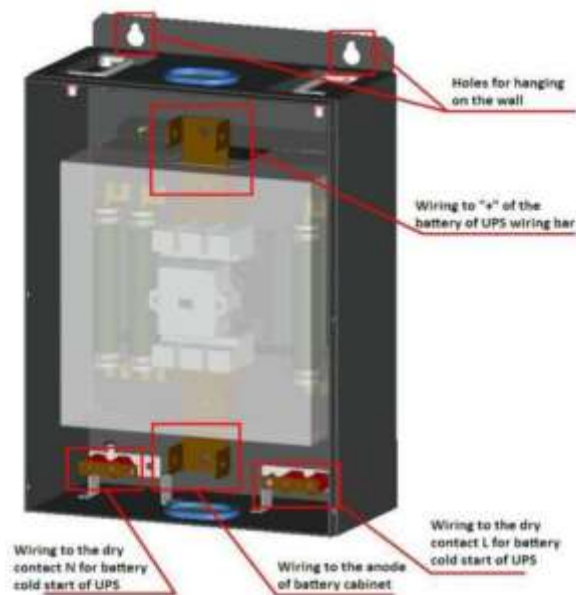

Fig. 3-25: Battery cold start option

Note: This series 10-120kVA UPS have been equipped with the standard battery cold start function. The battery cold start dry contact of This series (80-160kVA) UPS is in the lower right corner of the right inner door of the circuit board; the battery cold start dry contact of This series (200-300kVA) UPS is on the right of the terminal block of the UPS power line; the battery cold start dry contact of This series (400-500kVA) UPS is in the middle of the left inner door, and can be seen after opening the left inner door.

3.4.3 Brake unit system (optional)

The brake unit system is needed in occasions which have large load inertia and need to be stopped rapidly, such as elevators, textile machines, paper-making equipment, centrifuges, wire drawers, winding machines, proportional linkage systems, overhead cranes, mechanical fingers, conveyor belts, turning lathes, milling machines and other motors with positive and negative rotation functions or servo motors. All options are available for the complete series products. For details of the system configuration, please consult the manufacturer. Models of the brake unit system are shown in Fig. 3-26 and 3-27;

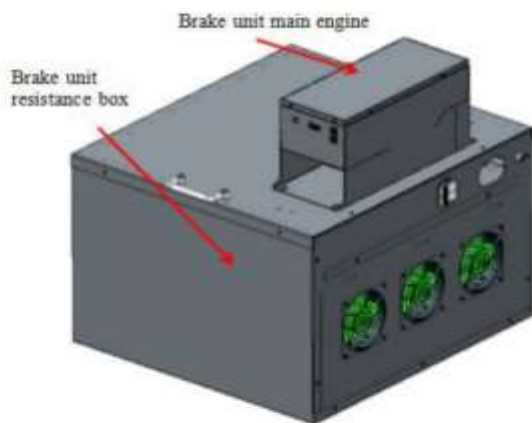

Fig. 3-26: Model of the brake unit system

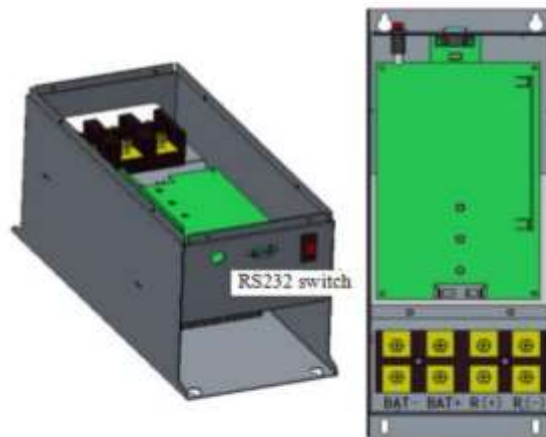

Fig. 3-27: Model of the brake unit main engine

The connection terminals of the brake unit system are shown in Fig. 3-28 and Fig. 3-29 below;

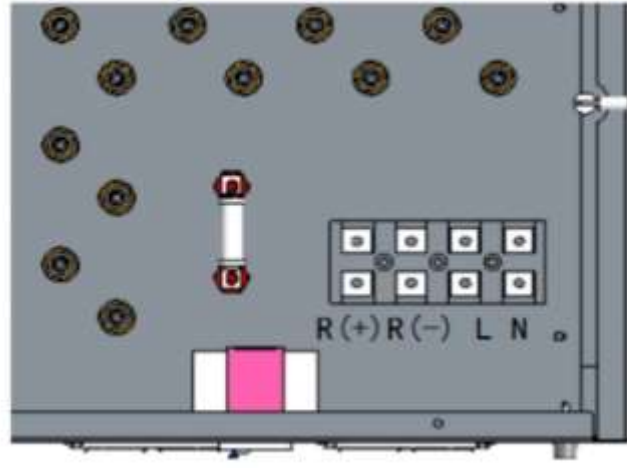
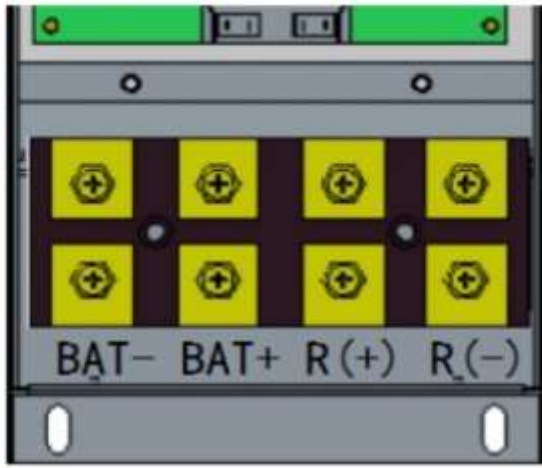

Fig. 3-28: Connection terminal of the brake unit main engine

Fig. 3-29: Connection terminal of the brake unit resistance box

Table 3-2, connection terminal

Port	Port definition	Port	Port definition	Port	Port definition
BAT-	Input cathode of the brake unit main engine	BAT+	Input anode of the brake unit main engine	R(+)	Output anode of the brake unit main engine
R(-)	Output cathode of the brake unit main engine	R(+)	Output anode of the brake resistance box	R(-)	Output cathode of the brake resistance box
L	Power line of the fan power supply	N	Null line of the fan power supply		

3.5 Power cable

When designing the external connection cables, the requirements for the current capacity of power cables and the overload capacity of the system should be considered, and the environmental temperature and physical support media should also be considered. Installation engineers should make a comprehensive selection according to the local regulations and standards as well as the actual situation of users. The connection cable is generally 2-50 meters long, since too long cables may cause low voltage, and the corresponding sectional area should be increased.

Table 3-2: UPS connection terminal and connection modes

Connection terminal	Rectifier input	Bypass input	Output	Battery (50 cells)
Connection mode	3Φ+PE	3Φ+N+PE	3Φ+N+PE	Anode + cathode + PE

Table 3-3: Rated current of this series (10-120kVA) UPS

Rated capacity (kVA)	Rated current (A)						
	Input current at full load and floating charge			Output current at full load (PF=0.9)			Discharge current at the lowest battery voltage
	R	S	T	U	V	W	
10	21	21	21	15	15	15	33
15	32	32	32	23	23	23	50
20	42	42	42	30	30	30	67
30	63	63	63	45	45	45	100
40	84	84	84	61	61	61	130
60	126	126	126	91	91	91	195
80	168	168	168	121	121	121	260
100	210	210	210	152	152	152	326
120	253	253	253	182	182	182	391

Table 3-4: Rated current of this series (80-500kVA) UPS

Rated capacity (kVA)	Rated current (A)						
	Input current at full load and full charge			Output current at full load (PF=0.9)			Discharge current at the lowest battery voltage
	R	S	T	U	V	W	
80	128	128	128	121	121	121	155
100	160	160	160	152	152	152	194
120	191	191	191	182	182	182	232
160	255	255	255	243	243	243	310
200	319	319	319	304	304	304	387
250	399	399	399	380	380	380	484
300	478	478	478	456	456	456	580
400	638	638	638	608	608	608	774
500	797	797	797	760	760	760	967

 **Note:**

- For the connection of external connection cables, please refer to the national or local electrical code.
- The cable between the battery and the UPS should not produce a voltage drop greater than 1% of the nominal DC voltage under the rated battery current.

3.6 External protective device

A circuit breaker or other protective device must be installed at the place of external power input of the UPS system. This chapter provides general guidance for installation engineers only. Installation engineers should understand local regulations on the wiring of the equipment to be installed.

Before the rectifier and bypass inputs are connected to the mains supply, a proper overcurrent protection

device must be installed between the mains supply and the UPS. According to the EN50091-1 standard, a leakage current protector with adjustable thresholds can be used for the leakage current of the UPS. For external batteries, a DC compatible circuit breaker should be equipped to provide overcurrent protection for the UPS and its batteries.

⚠ Note: if a leakage current protector is used to power the UPS, the very high leakage current generated by RFI filter may cause the false trigger of the protective device.

3.7 Connection terminal

When opening the front door of the UPS and removing the lower protective cover of the machine, you can see the terminal block connecting the power cable.

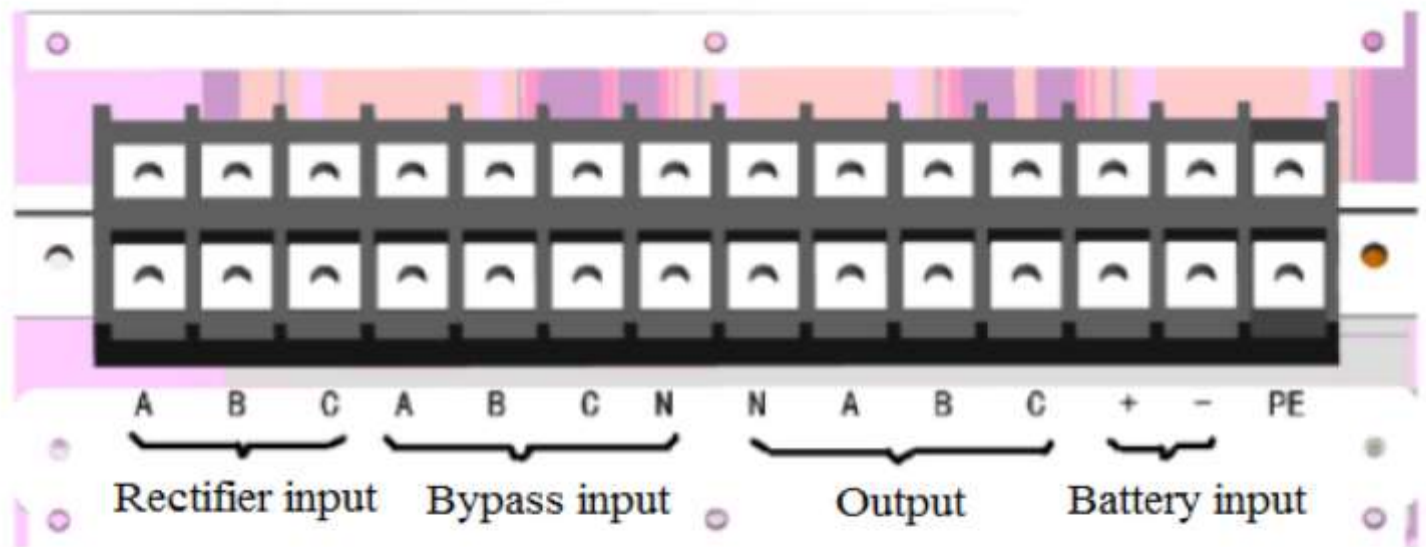

Fig. 3-30: Connection terminal of this series (10-40kVA) UPS

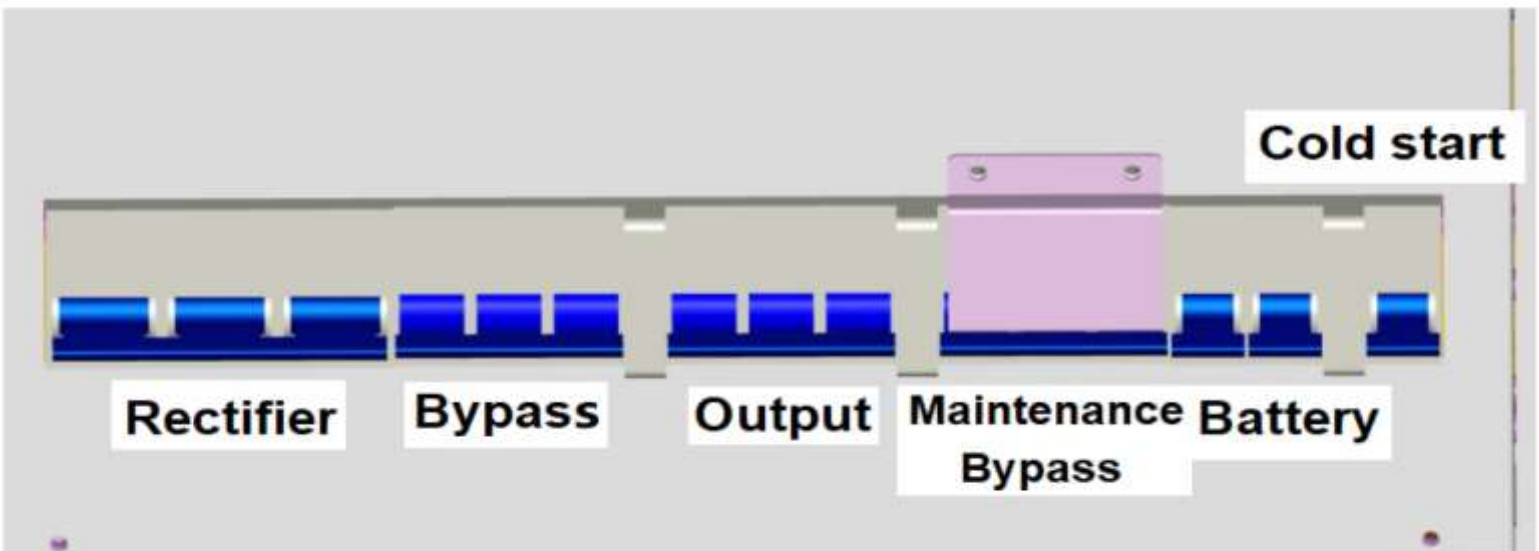

Fig. 3-31: Breaker of this series (10-40kVA) UPS

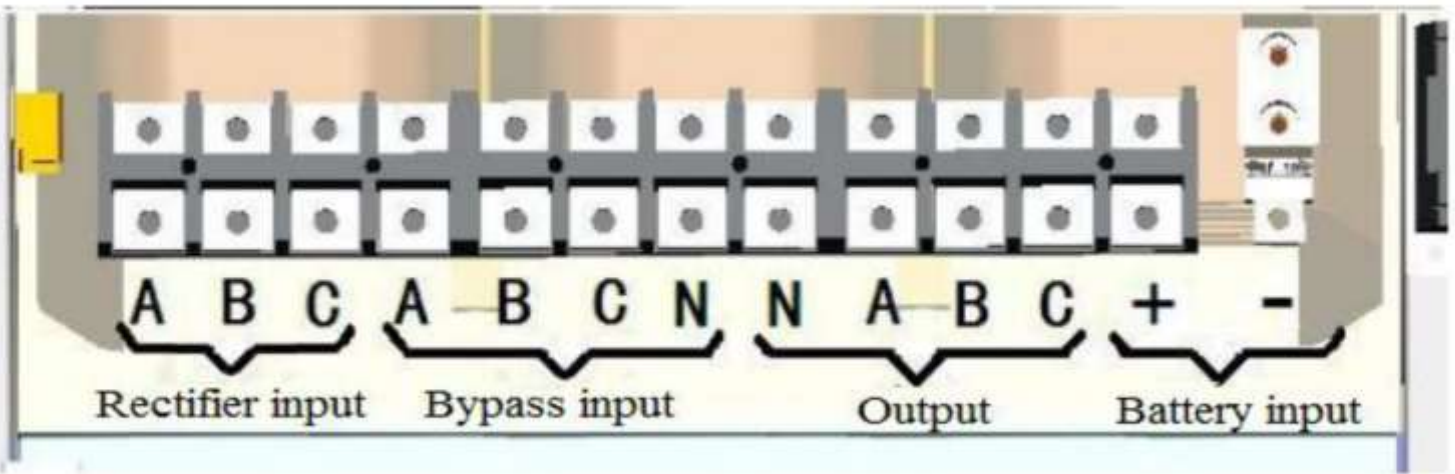

Fig. 3-32: Connection terminal of this series (60kVA) UPS

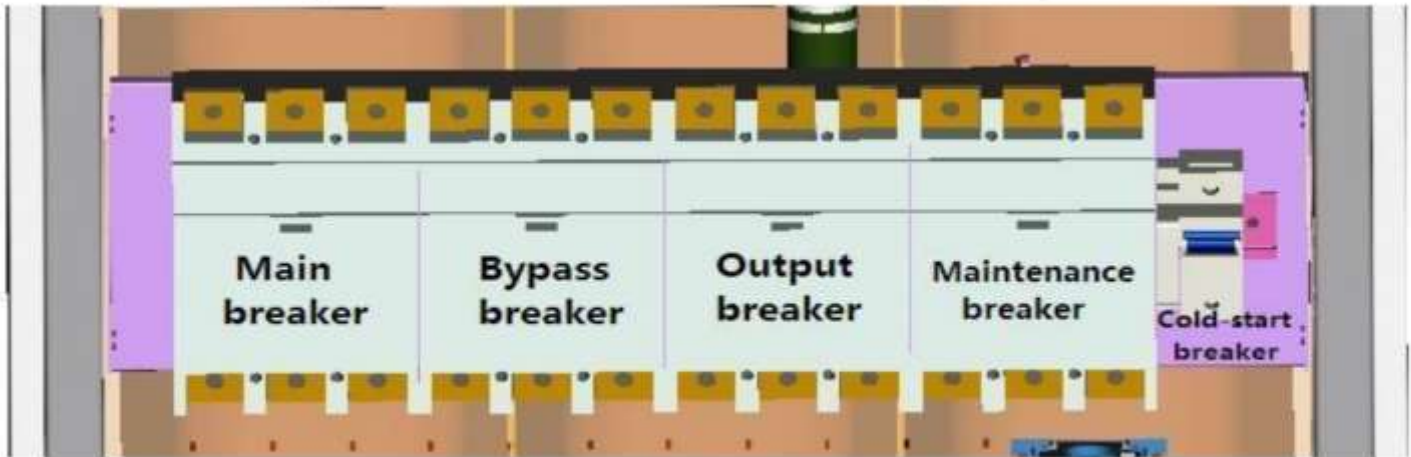

Fig. 3-33: Breaker of this series (60kVA) UPS

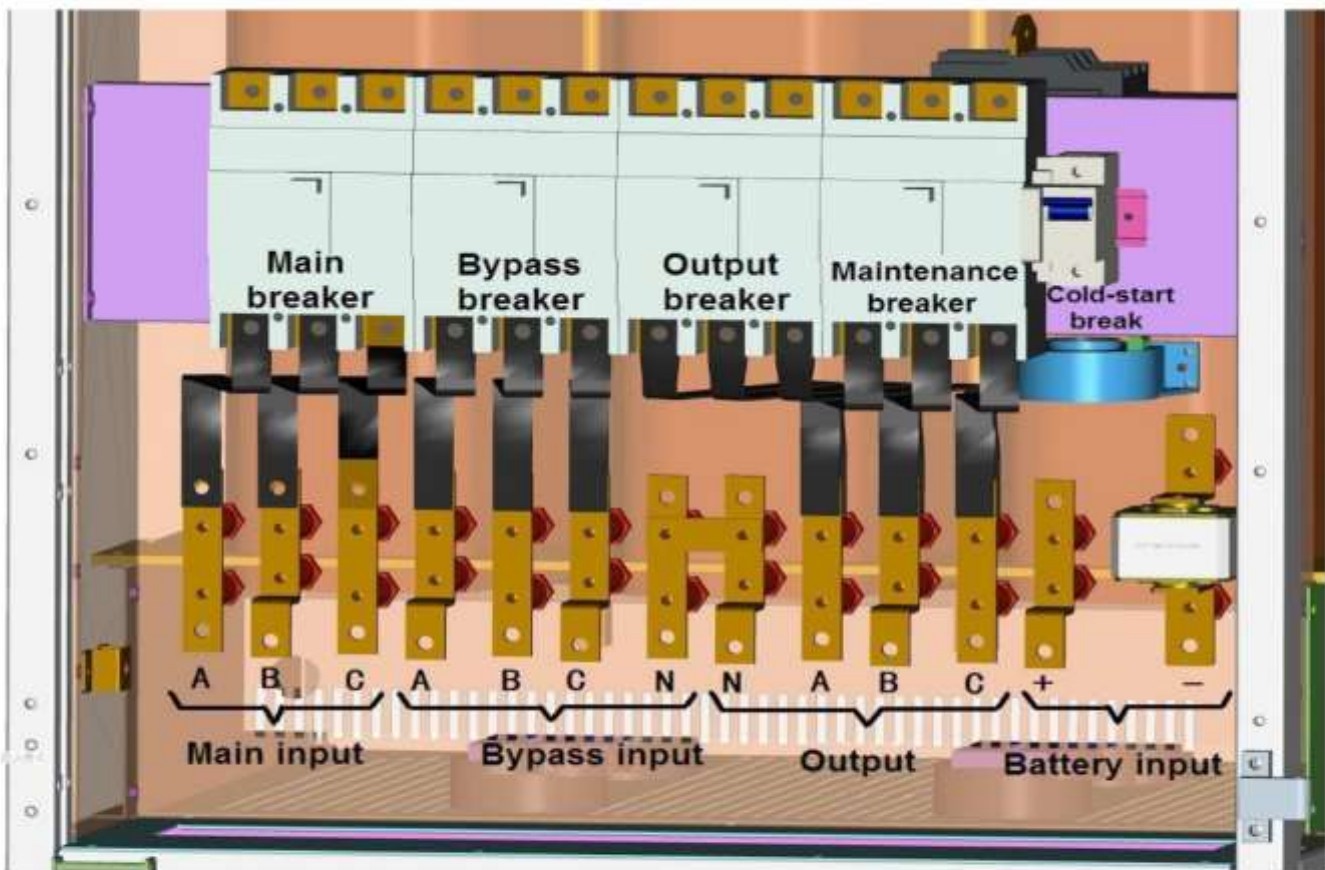

Fig. 3-34: Breaker of Connection terminal and this series (80-120kVA) UPS

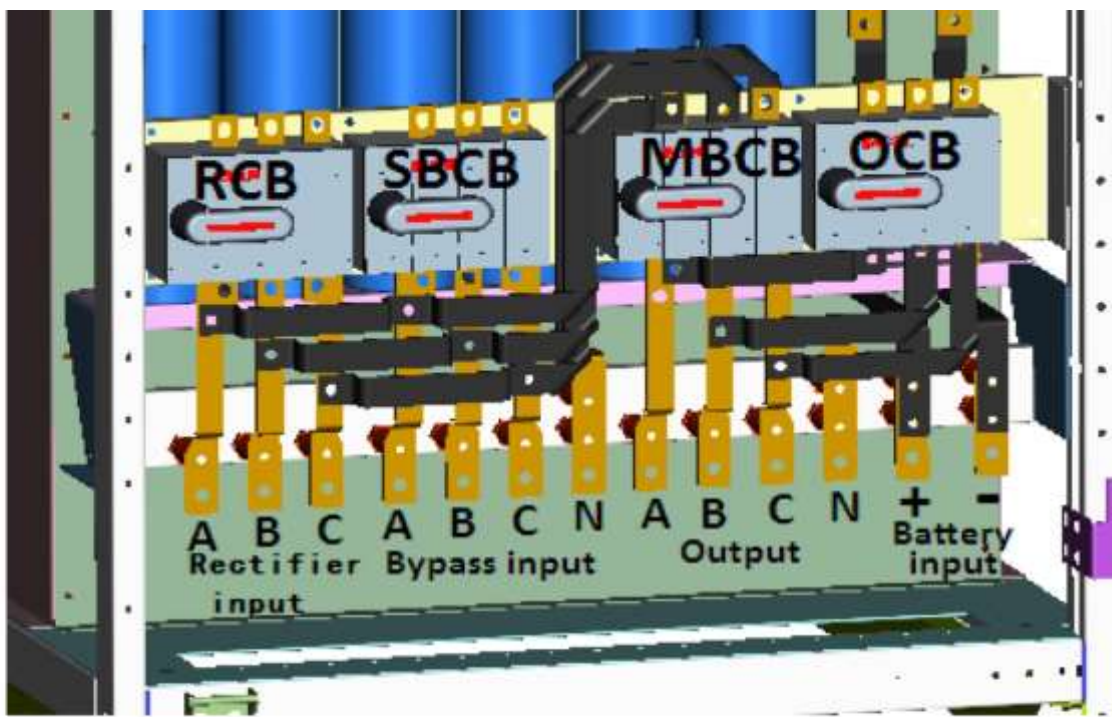

Fig. 3-35: Connection terminal of this series (160kVA) UPS

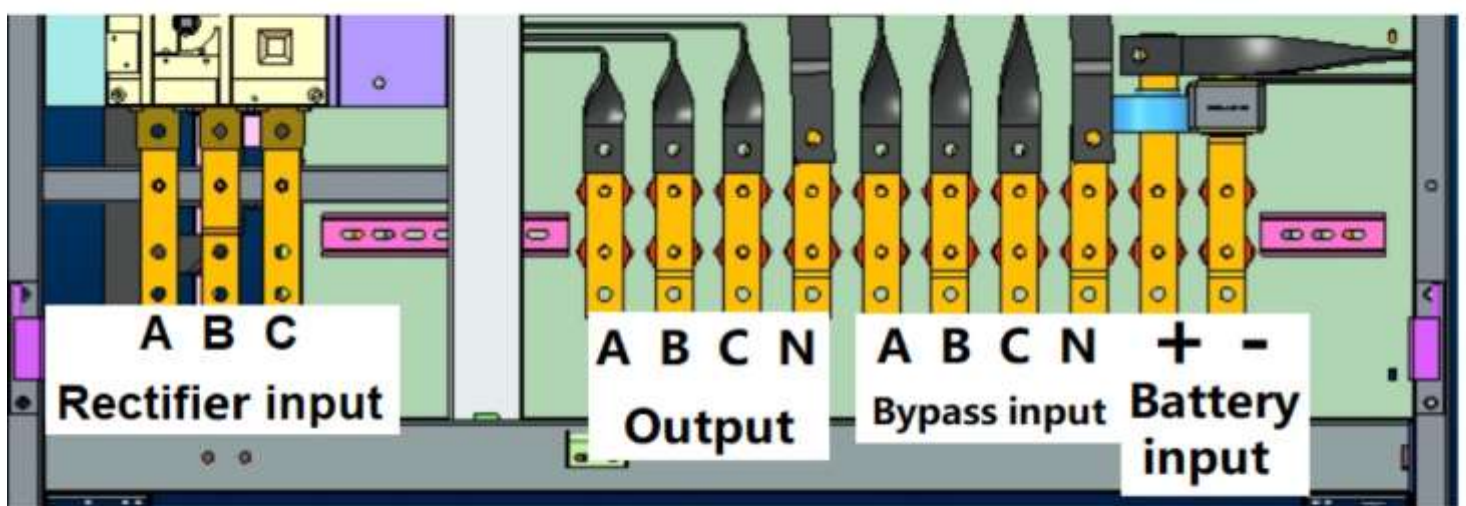

Fig. 3-36: Connection terminal of this series (200-300kVA) UPS

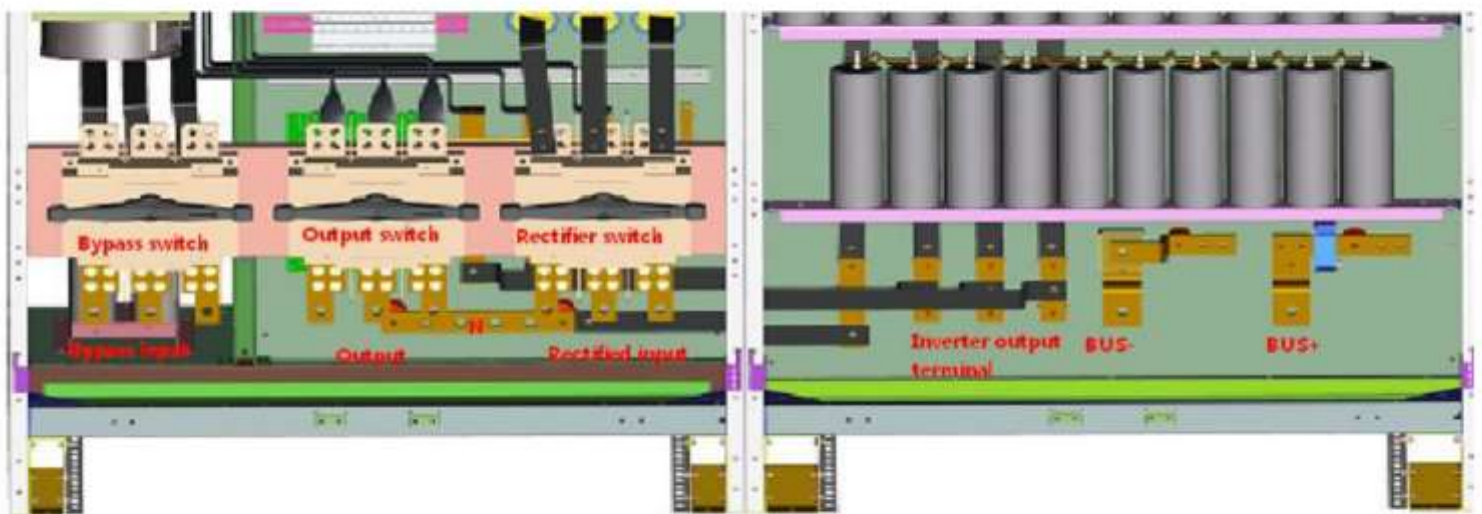

Fig. 3-37: Connection terminal of this series (400-500kVA) UPS

3.8 Wiring

3.8.1 Wiring of stand-alone system

After the device is completely positioned, the power lines are connected according to the following steps:



Note: when connecting the rectifier input line to the 200-300kVA machine, the screws should be fixed.

1. Ensure that all input distribution switches and internal power switches of the UPS are disconnected. Attach warning labels on these switches to avoid misoperation.
2. After opening the front door of the UPS, you can see the terminal connecting the power cable. For the 200-300kVA machine, the rectifier input terminal can be seen only after removing the switch protective cover in front of the disconnecting switch. The distance between the screw and the protective cover should be at least 3 cm to prevent accidents caused by ignition or short circuit with the machine box due to insufficient safety distance.
3. Connect the protective earthing wire and other necessary earthing cables to the earthing bolts of the base of the UPS power supply device. All UPS cabinets must be connected to the earthing lines of users.

The input cable is marked and connected by one of the following two steps (separated bypass or public input) according to the installation types:

Separated bypass connection

4. When the complete series products leave the factory, the mains input and bypass input have been separated. When connecting cables, you only need to connect cables of the bypass input and the mains input. Ensure that the phase sequence is correct when wiring.

Public input connection

5. When the same mains input is needed for the mains input and the bypass input, the 10-120kVA and 200-300kVA machines are connected with the provided short connecting line; the 160kVA machine is connected with the provided copper bar, and the switch plate needs to be removed before installation; no wire or copper bar is provided with the 400-500kVA machine, and users need to purchase it by themselves. Ensure that the phase sequence is correct when wiring.

System output connection

6. Connect the output cable between the UPS output terminal (OUTPUT: R/S/T/N) and the important load. Please ensure the safe insulation at the end of the system output cable if the load is not ready to receive the power supply when the commissioning engineer arrives at the site.

External battery connection

For battery connection, please refer to Chapter 4.5 in the EN50091-1 standard.

The battery cabinet must be connected to the protection ground separately.

7. Connect the battery cable between the (+B\B) battery terminal of the UPS and the battery switch. The

cable between the battery terminal and the battery switch should be connected from the switch first. Check the cable connection and tighten the bolts for locking the cable. Reinstall all protective covers after ensuring that the cable is correctly connected.

Dry contact signal connection

8. Connect the dry contact; the dry contact terminal is under the inner door of the rectifier cabinet. The dry contact is shown in Fig. 3-38. Dry contacts “1” and “2” are the wiring terminal of battery cold start (⚠ Note: This terminal is strongly charged when the UPS is running, and “1” is the power line and “2” is the null line). Dry contacts “4” and “5” are the wiring terminal of the auxiliary contact of the maintenance bypass (option), and dry contacts “6” and “7” are the wiring terminal of the undervoltage release of the battery switch. Note: some products only have the dry contacts of battery cold start and battery undervoltage release. The location and port definition are subject to the silkscreen logo.

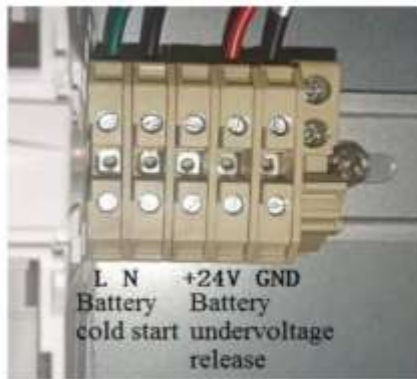

Fig. 3-38: Dry contact of this series (160-300kVA) Fig. 3-39: Dry contact of this series (400-500kVA)

3.8.2 Wire of parallel system

Diagram of parallel interfaces

This series have two types of parallel interfaces. The first parallel interface is on the parallel board. Insert the parallel wire directly into P1-P4 of the parallel board and tighten the set screws. The second parallel interface is on the inner door. Insert the parallel wire directly into P1-P4 of the parallel interface and tighten the set screws. As shown in Fig. 3-40 and Fig. 3-41

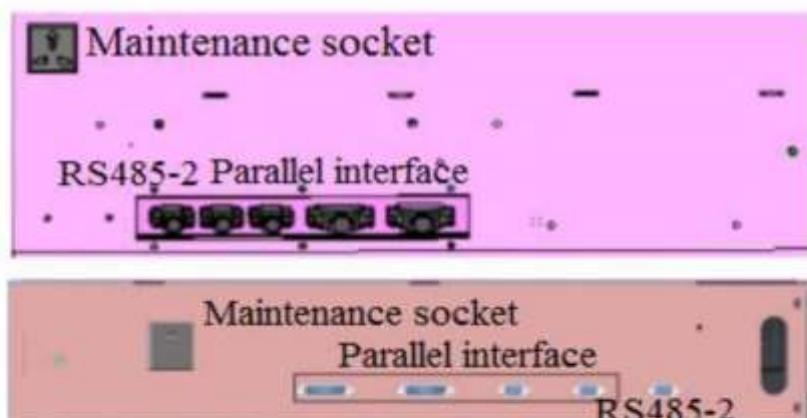
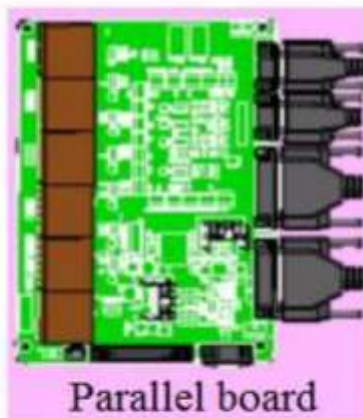

Fig. 3-40: Interface on the parallel board Fig. 3-41: Parallel interface on the inner door

Parallel signal line connection

Each machine has four parallel wire interfaces (including two DB25 and two DB9). In the parallel system, the parallel wire of DB25 should be connected into a closed loop, the same is true to DB9. Two parallel wires of the same loop should run in parallel and be not close to the power cable, so as to reduce the external interference to the parallel wires. The wiring diagram is shown in Fig. 3-42.

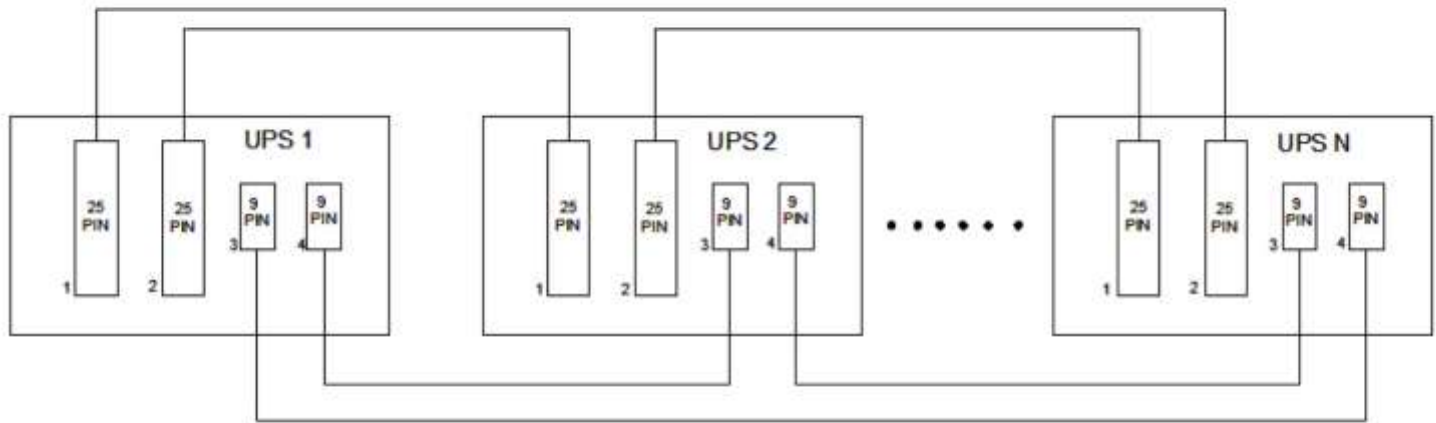

Fig. 3-42: Schematic diagram of parallel signal line connection

Parallel power cable connection

If there is only one power supply line, you can connect each machine by “public input connection”, and then connect the input terminals of all machines together and the output terminals of all machines together. The wiring diagram is shown in Fig. 3-37.

If you adopt the separated bypass connection, you must remove the copper bar in the machine that is short-circuited between the main circuit and the bypass, and then connect the rectifier input terminals of all machines together; you just ensure that the bypass input terminals are connected, and have to ensure that the phase sequence is correct.

⚠ **The method for battery cable connection is the same as that for the stand-alone machine. The battery of the UPS should not be shared.**

⚠ **Note:** in the configuration design of the parallel system, to achieve a better current sharing effect of the parallel UPS, the input cable and the output cable of each UPS must be of the same specification, and the power cable length from the input terminal to the AC distribution connection point should be consistent with that from the output terminal to the load connection point for each UPS, ensuring that the input and output impedances of each UPS are consistent.

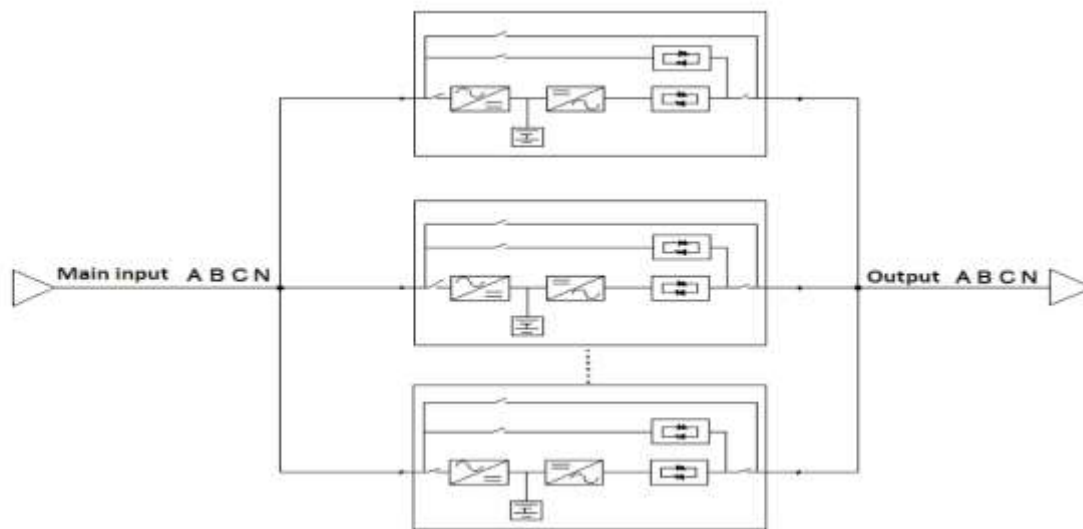

Fig. 3-43: Diagram of power cables of the parallel machine

3.9 Control cable and communication

3.9.1 Communication interface

According to the specific requirements of the site, we may need to provide auxiliary connection for the UPS to manage the battery system (battery temperature sensor), communicate with a personal computer, provide warning signals to external devices or realize such functions as remote emergency shutdown.

The communication interface module provides the following interfaces

Fig. 3-44: Communication interface diagram; Table 3-6: Definitions of communication interface port

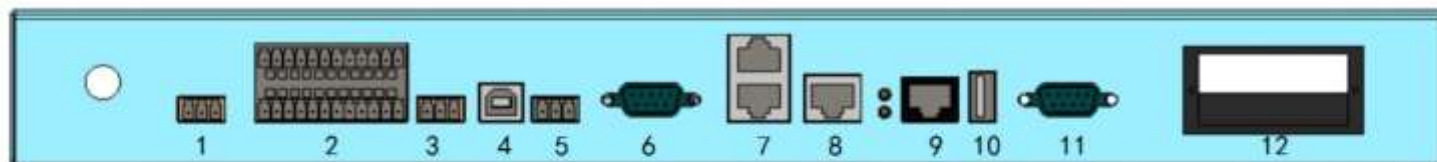

1	EPO interface (NO+NC)	2	Dry contact interface (DRY CONTACT)	3	Output dry contact interface (250V DRY)
4	USB interface	5	RS485-1 interface	6	RS232 interface
7	RS485 interface/CAN interface (BMS)	8	NET interface (undefined, reserved)	9	Battery temperature compensation interface
10	USB HOST interface	11	Monitoring display unit interface	12	Intelligent slot

Table 3-7: Definitions and functions of communication interface

RS232	An interface that provides serial data and is directly used for background monitoring of software. When users need to use the interface, they only need to connect it directly from the communication interface module using the provided USB cable.
RS485-1	An interface that provides serial data and is directly used for background monitoring of software. When users need to use the interface, they only need to connect it directly from the communication interface module using a serial USB cable. Pin 1: 485+; pin 2: 485-; pin 3: power ground.

RS485-2	A debugging and maintenance interface that provides serial data and is used to authorize the debugging and maintenance personnel. This interface has been connected to the communication interface module.
Intelligent Slot interface	This is a communication interface for the SNMP card, WIFI card and 4G card, which is used to install the communication option SNMP card on the site, so as to remotely manage the UPS via the Internet. This interface has been connected to the communication interface module.
RS485 interface CAN interface	A communication interface that provides the BMS and UPS of lithium batteries, which is used for BMS and UPS communication. The complete series product temporarily only supports the RS485 communication with the fixed protocol.

3.9.2 Definition of dry contact

Table 3-8: Definition of input and output dry contact port

Port name	Signal definition	Closure conditions
EPO	EPO(NO+NC)	—
IN-1 (customizable)	Default function: power off	—
IN-2 (customizable)	Default function: power on	—
IN-3(Can not be set)	Shutdown	—
IN-4(Can not be set)	Manual bypass	—
IN-5(Can not be set)	Reserved	—
IN-6(Can not be set)	Reserved	—
OUT-1 (customizable)	Default function: Fan fault	Fan failure
OUT-2 (customizable)	Default function: Faults and Alarms	Fault alarm
OUT-3 (customizable)	Default function: power on	Power on
OUT-4 (customizable)	Default function: Battery low voltage	Battery low voltage
OUT-5 (customizable)	Default function: Output overload	Output overload
OUT-6 (customizable)	Mains mode (NO+NC)	Mains mode

Table 3-9: Function description of dry contact

Dry contact interface	Signal description	Status Description
Input dry contact IN1~IN2	None	undefined
	power on	When the input signal is valid, the UPS will power on
	Generator auxiliary contact	When the input signal is valid, the UPS detects that the generator is connected.
	Battery auxiliary contact	The UPS detects that the battery switch is closed when the external battery switch (auxiliary contact of the switch needs to be added) is closed.
	Maintenance bypass auxiliary contact	When the external maintenance switch (the auxiliary contact of the switch needs to be added) is closed, the UPS detects that the maintenance bypass switch is closed.

	Start test program	The input signal is valid and the "master control test enable" is valid, and the UPS enters the engineering commissioning mode. This function is used for UPS detection and maintenance, and it is prohibited for non-professionals to operate.
	Output switch auxiliary contact	When the external output switch (auxiliary contact of the switch needs to be added) is disconnected, the UPS detects that the output switch is disconnected.
Output dry contact OUT1~OUT5	None	undefined
	Fan fault	In case of fan failure, the dry contact will act. When the fan fault disappears, the dry contact is restored.
	power on	In the startup state, the dry contact acts. Shutdown state, dry contact recovery.
	Battery low voltage	When the battery low voltage alarm occurs, the dry contact acts. When the battery low voltage alarm disappears, the dry contact will be restored.
	Start the generator	When the battery voltage is lower than the preset generator starting voltage, the dry contact acts (that is, the generator needs to be started). When the voltage is higher than the preset generator shutdown voltage, the dry contact will recover (that is, the generator needs to be shut down)
	Power off according to time	When the rectifier input and bypass input are abnormal at the same time, the dry contact acts. When either rectifier input or bypass input is recovered, the dry contact is recovered.
	Battery low voltage disconnection	When the battery voltage is lower than the set tripping voltage of the release, the dry contact acts. When the battery voltage is higher than the set release recovery voltage, the dry contact will recover.
	Bypass contactor	When the bypass voltage is normal, the dry contact acts. When the bypass voltage is abnormal, the dry contact shall be restored.
	Heating equipment1/2/3	The internal temperature of the lithium battery is lower than the preset value, and the dry contact acts. The internal temperature of lithium battery is higher than the preset value, and the dry contact is restored. It is only valid when the communication between UPS and BMS is normal.
	Faults and Alarms	When a fault or alarm occurs, the dry contact acts. When the fault or alarm disappears, the dry contact will recover.
	Over load	When the output overload occurs, the dry contact acts. When the output overload disappears, the dry contact will recover.
	Battery contactor	The battery voltage is higher than the preset battery contactor pull in voltage, and the dry contact acts. The battery voltage is lower than the preset battery contactor disconnection voltage, and the dry contact is restored.
Output dry contact OUT6	None	undefined
	Mains mode	Mains mode, dry contact action. Non mains mode, dry contact recovery.
	Bypass mode	Bypass mode, dry contact action. Non bypass mode, dry contact recovery.
	Battery mode	Battery mode, dry contact action. Non battery mode, dry contact recovery.

1. The input dry contact interface includes power on, power off, bypass output and emergency power off (EPO). Customizable functions of IN-1 and IN-2: disable the dry contact function, power on, generator

access (auxiliary contact), battery switch closure (auxiliary contact), external maintenance bypass closure (auxiliary contact), external output switch closure (auxiliary contact), start test procedure (used in the engineering commissioning mode). When the above functions are used, shield cables must be connected to avoid interference caused by misoperation, thus leading to load power failure or other effects. If you do not need to use this function, please keep the input dry contact terminal disconnected.

2. The output dry contact includes the running mode and fault warning of the machine. Customizable functions of OUT-1 to OUT-5: heating rod function, fan failure, power on, battery low voltage, turn on generator, time-sharing power supply, battery undervoltage release, bypass contact closure (UPS internal control signal), battery contactor control signal (UPS internal control signal). OUT-6 customizes the mains mode, battery mode and bypass mode.
3. Each input dry contact terminal provides the normally open switch and normally closed switch. OUT-1 to OUT-3 default to normally open contacts, and OUT-4 to OUT-6 default to normally closed contacts. Users can select the default functions according to their actual demands.

⚠ The following aspects should be noted when connecting auxiliary cables:

- If conduits are used for connection, they should be used separately for communication lines and power lines.
- Remote EPO switches must be connected in accordance with local regulations.
- The auxiliary cables must be insulated and stranded. When the wiring distance is 25-50m, the sectional area should be 0.5-1.5 mm².

3.9.3 Emergency power off input interface (EPO)

As shown in Fig. 3-38, the EPO input dry contact is the remote EPO input interface. UPS provides the emergency power off (EPO) function (EPO can be set to “interrupt output” and “convert to bypass”; the default mode is “transfer to bypass”). This function is realized through the remote contact provided by the user.

⚠ Note: when the EPO is set to “interrupt output”, and the emergency power off (EPO) is performed, the UPS system cuts off the load power supply

This function can be used only when you are sure to disconnect the UPS output.

⚠ Note: The Emergency Power Off (EPO) of the UPS turns off the rectifier, inverter and static bypass, but it does not disconnect the input mains supply of the UPS from the inside. If you need to completely power off the UPS, you just disconnect the lower-level input switch when triggering the EPO.

3.10 Maintenance socket

Some products are equipped with standard maintenance sockets. Maintenance sockets can supply power to tools that require power supply when the maintenance personnel maintain the machine (220V/50Hz). For example, the electric soldering iron, and digital oscilloscope. The maximum current that can pass through the maintenance socket is 5A.

Note:

- **The default action mode of the emergency power off (EPO) is “transfer to bypass”. When operating the EPO, the UPS system transfers to the bypass output. If you need to set the action mode of the EPO to “interrupt output”, please set it correctly before power on. The function of “interrupt output” can be used only when you are sure to disconnect the UPS output.**
- **When performing the “maintenance bypass output”, the UPS system sets the manual bypass to “ON” to switch to the bypass mode. To turn off the manual bypass, you should turn off it the monitoring panel.**
- **When the UPS is in bypass mode, the load is not protected by the UPS in case of voltage or frequency fluctuation or power failure.**

Chapter Four: Operation Manual

Before starting the UPS, you must ensure that the machine has been installed by the authorized maintenance engineers and checked that all electrical connections are normal to ensure the normal operation of the system. After the UPS is started successfully, you can operate it according to the running mode in Chapter Two. This chapter describes the operation steps by operators in various running modes, including startup/shutdown steps of the UPS, switching the load to the bypass, entering and exiting from the maintenance bypass, parallel operation steps and so on.

 **Note:** For all user operation keys and LED display involved in operation steps, please refer to Chapter Five.

 **Note:** Before performing any of the operation steps described in this chapter, please carefully read the instructions to avoid the personal injury or equipment damage caused by misoperation.

4.1 The first starting the UPS

The first starting the UPS or the device to restore factory settings after the reboot can be quickly set. as shown in Fig. 4-1. The specific quick setting interface includes language setting, display setting, system setting 1, system setting 2. After the quick setup, go to the home screen.

Fig. 4-1: Quick setup interface



4.2 Start up steps (enter the inverter power supply mode)

Start up steps of the UPS are used to start the UPS which has been completely powered off, that is, the load has not been powered through the UPS or maintenance switch. Here, we assume that the UPS has been installed and debugged by engineers, and the external switches have been closed.

Warning:

- **The UPS input and output terminals may be electrically charged with this operation, so you should be careful.**
- **If you need to disconnect the lower-level load connection, please attach a warning mark at the load connection.**
- **The parts behind the protective cover that can be opened only by using tools are non-operable.**
- **Only qualified maintenance personnel are allowed to open the protective cover.**

1. Ensure that all switches of the UPS are disconnected.
2. Close the UPS bypass switch. After the display screen is normal, the system is in a standby mode. The “Control ” in the monitoring display interface is grayed. You can click the password lock in the upper right corner of the display interface, an unlock window pops up, and then you can enter the password (the initial password is “123456” if it is not changed by the user), as shown in Fig. 4-2. After unlocking, you can choose “Control” from the main menu of the monitoring display unit, click “POWER ON” and choose “YES”, as shown in Fig. 4-3. After the operation, the bypass output of the UPS starts.



Fig. 4-2: Password input interface



Fig. 4-3: Startup confirmation interface

3. Close the rectifier input switch. After about 10 s, the rectifier starts to run normally and the inverter starts the soft-start. After about 3 s, the inverter starts to work normally, and the UPS switches from the static bypass power supply mode to the inverter power supply mode.
4. Close the external the battery switch. The battery switch is near the battery cabinet or battery rack. After the UPS system detects that the battery has been connected, the battery energy chart on the main interface starts to flow (indicating that the battery is being charged), and the battery icon changes from white to green. View the battery data on the LCD panel to check whether the battery voltage displayed is consistent with the actual value. At this time, the energy flow chart on the main interface is shown in Fig. 4-4.

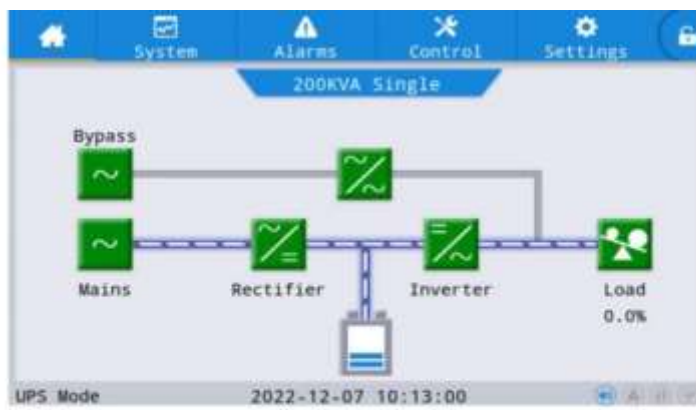

Fig. 4-4: Energy flow chart of the rectifier and inverter during working

5. Confirm that no warning information is displayed in the warning menu, the UPS is in the inverter mode, and then close the output switch and confirm the UPS output parameters.

4.3 Shutdown steps (completely close the UPS and loads)

The UPS is completely shut down and the load is powered off according to the following steps. After the operation, all power switches and circuit breakers are disconnected, and the UPS does not supply power to loads.

1. Close or disconnect all loads of the UPS.
2. After starting the display screen, the “Control” on the monitoring display interface is grayed. You can click the password lock in the upper right corner of the display interface, an unlock window pops up, and then you can enter the password (the initial password is “123456” if it is not changed by the user), as shown in Fig. 4-5. After unlocking, you can choose “Control” from the main menu of the monitoring display unit, click “SHUT DOWN” and choose “YES”, as shown in Fig. 4-6. After the operation, the rectifier, inverter and static switch are shut down, and the UPS has no output.



Fig. 4-5 Password input interface



Fig. 4-6 Inverter shutdown pop-up window interface

3. Disconnect the rectifier switch, bypass switch, output switch and battery switch.
4. When the UPS is powered off, the LED indicator on the panel is off, and the LCD displays stops.
5. To completely power off the UPS, you must disconnect the external mains distribution switch and external output switch, and attach the warning mark.

4.4 Turning on and off the ECO mode

If you want the UPS run in the ECO mode, please set the UPS in the ECO mode before startup, and it will take effect after setting.

4.4.1 Steps of turning on the ECO mode

1. Set the ECO working mode

After starting the display screen, if the “Settings” on the main menu of the monitoring display unit is grayed, you need to unlock it. You can click the password lock in the upper right corner of the display interface, an unlock window pops up, and then you can enter the password, as shown in Fig. 4-2. Click [Settings]→[Advanced]→[working mode]→[ECO MODE] on the main menu of the monitoring display unit, as shown in Fig. 4-6. After restarting the UPS, you should observe the energy flow chart on the main page. When the energy flow chart is shown in Fig. 4-7, the current UPS working mode is the ECO mode.



Fig. 4-7 Setting of the ECO mode

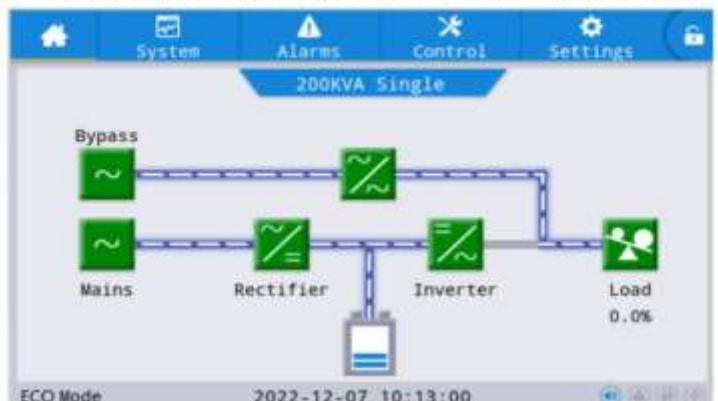

Fig. 4-8 Energy flow chart of the ECO mode

4.4.2 Steps of turning off the ECO mode

If you want to exit from the ECO mode and return to the mains mode, you can click [Settings]→[Advanced]→[working mode]→[UPS MODE] on the main menu of the monitoring display unit, as shown in Fig. 4-7.

4.5 Operation steps of maintenance bypass

⚠ Note: please carefully read the warning information in Chapter One and operate the maintenance bypass with caution. Otherwise, the UPS may be damaged, or the loads may be powered down, and the personal safety may be threatened.

4.5.1 Enter the maintenance mode (stand-alone machine)

Specific operation steps are as follows:

Notes	
	<ul style="list-style-type: none">In the bypass power supply mode, when the input voltage or frequency range exceeds the default value, the system may have no output and the load may be

powered off.

- You need to ensure that the bypass is normal before manually transferring to bypass. If the bypass is abnormal, the “manually transfer to bypass” is ineffective and the previous status is retained.

1. Start the “manually transfer to bypass”. After starting the display screen, if the “Control” on the main menu of the monitoring display unit is grayed, you need to unlock it first. You can click the password lock in the upper right corner of the display interface, an unlock window pops up, and then you can enter the password, as shown in Fig. 4-1. Choose the “Control” on the main menu of the monitoring display unit, click the [Manual to bypass-on], and select the “YES”, as shown in Fig. 4-9. At this time, UPS powers the load by static bypass, and the energy flow chart is shown in Fig. 4-10.

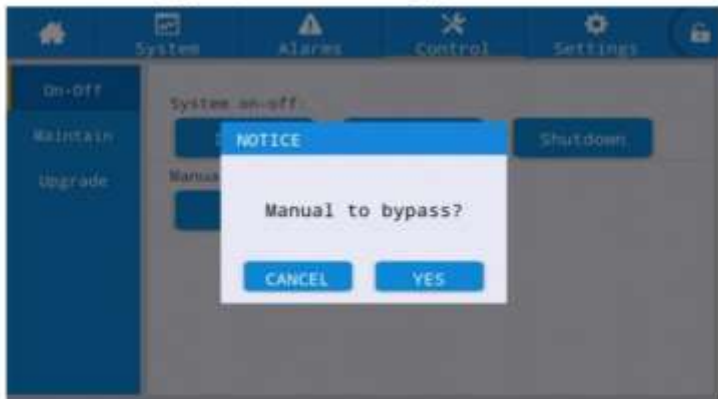

Fig. 4-9 Setting interface of manual bypass

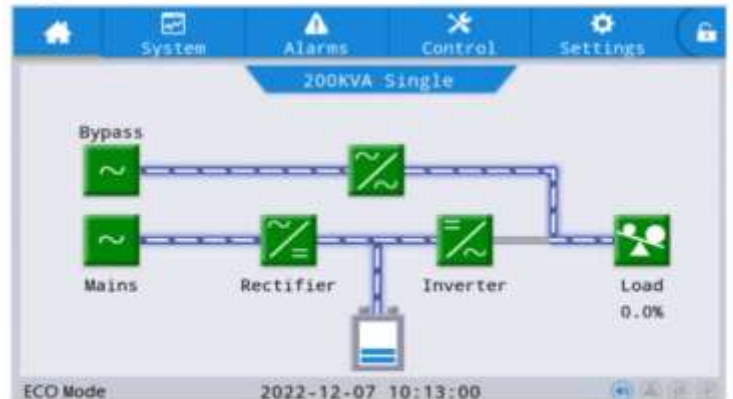

Fig. 4-10 Effective energy flow chart of manual bypass

2. Manually close the maintenance switch. At this time, the power is supplied by the maintenance bypass power supply and the UPS static bypass power supply in parallel to loads. After the operation, you can view the energy flow chart on the main page. When the energy flow chart is as shown in Fig. 4-8, UPS successfully enters the maintenance bypass mode.
3. Turn off the UPS. After starting the display screen, the “Control” on the monitoring display interface is grayed. You can click the password lock in the upper right corner of the display interface, an unlock window pops up, and then you can enter the password (the initial password is “123456” if it is not changed by the user), as shown in Fig. 4-1. After unlocking, you can choose “Control” from the main menu of the monitoring display unit, click “SHUT DOWN” and choose “YES”, as shown in Fig. 4-6. After the operation, the rectifier, inverter and static switch are closed, the UPS has no output, and the loads are powered by the maintenance bypass.
4. Manually disconnect the rectifier switch, bypass switch, external battery switch and output switch. At this time, the maintenance bypass switch is still closed.
5. Then, the operation of switching the UPS output to the maintenance bypass has been completed, the loads are powered by the maintenance bypass, the fan of the complete machine stops and the UPS is completely shut down. After the bus voltage is lower than 36V (about 10 min), the maintenance personnel can perform daily maintenance or repair on the UPS, but the load device is not protected by

the UPS.

4.5.2 Exit from the maintenance mode (stand-alone machine)

When the maintenance work is completed, you can perform the following operations to switch loads from the maintenance bypass mode to the inverter power supply mode.

1. Carefully check that no object is left in the UPS cabinet, and the internal connection line of the UPS is restored to the state before the maintenance.
2. Close the bypass input switch and rectifier input switch. After starting the display screen, the “Ccontrol” on the monitoring display interface is grayed. You can click the password lock in the upper right corner of the display interface, an unlock window pops up, and then you can enter the password (the initial password is “123456” if it is not changed by the user), as shown in Fig. 4-1. After unlocking, you can choose “Ccontrol” from the main menu of the monitoring display unit, click “POWER ON” and choose “YES”, as shown in Fig. 4-2. During the startup of the UPS, you should carefully observe whether the rectifier and inverter of the UPS are working normally: if they are working normally, you can continue the following steps; if they are not working normally, you should shut down the UPS, disconnect the rectifier input switch and bypass switch, and continue the maintenance work.
3. Choose the “Ccontrol” on the main menu of the monitoring display unit, and check whether the [Manual to bypass-on]. If not, you should set it to “on”.
4. Close the output switch and the battery switch. At this time, the power is supplied by the maintenance bypass power supply and the UPS static bypass power supply in parallel to loads.
5. Confirm that the battery is connected and the charging voltage and current are normal; the bypass output of the UPS is normal, and the loads are powered by the bypass and maintenance bypass of the UPS in parallel; disconnect the maintenance switch when no abnormal warning information is generated by the UPS.
6. Set the “ [Manual to bypass-OFF]” on the panel. At this time, the operation of exiting from the maintenance status is completed, and loads are switched from the status of not being protected by AC power supply to the status of being protected by the UPS.

4.6 Battery cold start steps (optional)

1. In the case of no mains input, if you need to start the UPS directly with the battery, you must configure the battery cold start option. Here, we assume that the battery cold start option has been normally connected to the UPS and battery cabinet. The startup steps are as follows:
2. Close the external the battery switch.
3. After starting the display screen, the “Control” on the monitoring display interface is grayed. You can click the password lock in the upper right corner of the display interface, an unlock window pops up, and

then you can enter the password (the initial password is “123456” if it is not changed by the user), as shown in Fig. 4-2. After unlocking, you can choose “Control” from the main menu of the monitoring display unit, click “POWER ON” and choose “YES”, as shown in Fig. 4-3. After the operation, the inverter is started in about 3 seconds, and the battery contact is closed. After 10 seconds, the inverter output of the UPS starts.

 **Note: only products equipped with battery cold start (some products are optional) can be powered on with batteries.**

4.7 Brake unit system (optional)

The brake unit system is needed in occasions which have large load inertia and need to be stopped rapidly. This option can consume the backflow energy generated by loads to avoid the overvoltage protection or damage triggered by the machine due to the backflow energy and ensure the normal operation of the machine.

1. Connect the power cable and fan power supply cable between the UPS and the brake unit system, and check whether the cables are correctly connected.
2. After the UPS starts normally, you should close the power switch of the brake unit main engine; after the display screen is displayed normally, the brake unit system enters the standby state.

Users can view the set parameters of the brake unit on the display interface, and also set such parameters as the initial braking voltage, end braking voltage and braking ratio using keys of the brake unit main engine.

Parameters of the brake unit main engine have been set before leaving the factory. To reset the parameters, please refer to the instructions of the brake unit system.

4.8 Manual battery maintenance

To prolong the battery life, you are advised to manually maintain the battery every 3 to 6 months. Steps of entering the manual battery maintenance are as follows:

1. After starting the display screen, the “Ccontrol” on the monitoring display interface is grayed. You can click the password lock in the upper right corner of the display interface, an unlock window pops up, and then you can enter the password (the initial password is “123456” if it is not changed by the user), as shown in Fig. 4-1. After unlocking, you can select the “Ccontrol” on the main menu of the monitoring display unit, and click the “Maintain”. According to the user requirements, you can select one of the three functions: “TSET T.” “TSET V.” and “TSET LOW”. After the operation, the rectifier of the UPS is in a standby state, the battery is discharged, and the energy flow chart on the main page shows the battery discharge status.

2. After the manual battery maintenance, the rectifier and inverter of the UPS are normally started, the output is switched to the inverter output without interruption, and the battery is charged. If the test needs to be stopped, the maintenance personnel only needs to select the “CLR TEST” in the menu “TEST CMD” to stop the manual battery maintenance, and then the UPS restores to the normal working mode.

Note: if the manual battery maintenance mode is used, the battery will discharge automatically, the backup time will be shortened, and the UPS output may be switched to bypass output. Please use the manual battery maintenance mode when the mains and bypass outputs are stable. If an exception occurs, please operate the “terminate test”.

4.9 Emergency power off (EPO) steps

There are two modes of EPO actions, and the default mode is “transfer bypass output”. If the mode of “interrupt output” is needed, please set the EPO action mode to “interrupt output” before startup. At this time, if the EPO is operated, the UPS will shut down the rectifier and inverter, the system will have no output, and loads will be powered down.

4.9.1 Emergency power off (EPO) operation

When removing the dry contact connector at the interface of the normally closed terminal of the EPO or closing the EPO switch connecting the dry contact to the outside, the UPS enters the emergency power off status. The emergency power off (EPO) switch is used to turn off the UPS in an emergency (such as fire and flood). The system will shut down the rectifier and inverter, and quickly switches to the bypass output status, and the battery stops charging or discharging.

4.9.2 Emergency power off (EPO) recovery

The UPS must be completely powered off, that is, all input switches (including the battery switch) must be manually disconnected, before the UPS exits from the emergency power off status.

 **Note: when performing the emergency power off (EPO) (EPO is set to “interrupt output” mode), the UPS system will cut off the load power supply (interrupt output). This function can be used only when you are sure to disconnect the UPS output.**

 **If there is still mains input to the UPS, then the UPS control circuit is still powered on, but the UPS output has been off. To cut off the mains supply of the UPS, you should disconnect the external mains input switch of the UPS.**

4.10 Steps of turning on/off parallel machine

4.10.1 Precautions for parallel operation

- When the parallel system is running normally, you are not allowed to plug or unplug the parallel

cable.

- **Before loaded, output switches of all machines in the parallel system must be closed, and all output terminals must be connected. After loaded, output switches (including the output switch of users' power distribution cabinet) of all machines in the parallel system should not be disconnected, unless the machine is shut down.**
- **Before using the maintenance bypass, you should set the “Manual to bypass” to on in all machines in the parallel system, and then close the maintenance switch.**
- **In the parallel operation, the bypass of all machines in the parallel system must be from the same power supply, and the bypass switches must be in the same status.**

4.10.2 Startup steps of the parallel system

1. Ensure that power of all machines is connected, and parallel cables and signal cables are correctly connected;
2. Close the bypass switches of all machines in the parallel system;
3. Close the output switch of UPS1 first, and then close the rectifier switch of the UPS-1. After starting the display screen, the “Ccontrol” on the monitoring display interface is grayed. You can click the password lock in the upper right corner of the display interface, an unlock window pops up, and then you can enter the password (the initial password is “123456” if it is not changed by the user), as shown in Fig. 4-1. After unlocking, select the “Ccontrol” on the main menu of the monitoring display unit, click the “POWER ON”, and select the “YES”. After about 15S, the inverter output of the machine starts; then close the battery switch of the UPS1.
4. Please turn on the UPS-2, UPS-3.....UPS-N parallel machine in the order of step 3;
5. After all machines are turned on, their indicators are identical to those of the UPS1. Then, the startup of the parallel system is completed;
6. Before loaded, you should ensure that output switches of all machines in the parallel system are closed, and all output terminals are connected;
7. If you want to add a stand-alone machine to the parallel system, please refer to step 2 and step 3.

4.10.3 Shutdown steps of the parallel system

1. Close all loads;
2. After starting the display screen, the “Ccontrol” on the monitoring display interface is grayed. You can click the password lock in the upper right corner of the display interface, an unlock window pops up, and then you can enter the password (the initial password is “123456” if it is not changed by the user), as shown in Fig. 4-1. After unlocking, you should select the “Ccontrol” on the main menu of the monitoring display unit, click the “SHUT DOWN”, and select the “YES”. This operation will turn off the rectifier and inverter, and disconnect the static switch, and the UPS1 will not continue to supply

power to loads. Please perform the operation with caution. After the machine is shut down, you should disconnect the output switch, battery switch, rectifier switch, and bypass switch of the UPS1;

3. Close the UPS-2, UPS-3UPS-N parallel system according to step 2;
4. If you want a stand-alone machine exit from the parallel system, please perform the operation according to step 2 in this section.

4.10.4 Operation steps of maintenance mode of parallel system

1. Set the “Manual to bypass” of UPS-1, UPS-2, UPS-3.....UPS-N to on in sequence. The operation is as follows: after starting the display screen, if the “Control” on the main menu of the monitoring display unit is grayed, you need to unlock it. You can click the password lock in the upper right corner of the display interface, an unlock window pops up, and then you can enter the password, as shown in Fig. 4-1. Choose the “Control” on the main menu of the monitoring display unit, click the “Manually to bypass-on”, and select the “YES”. At this time, all UPS manual bypasses in the parallel system have been set to on, and the system supplies power to loads through static bypass.
2. After closing the maintenance switch of the machine to be maintained, you should start the display screen, select the “Control)” on the main menu of the monitoring display unit, click the “SHUT DOWN”, and select the “YES” to shut down the machine. After shutdown, you should disconnect the output switch, the battery switch, rectifier switch, and bypass switch of the machine.
3. After the machine is completely powered down and the electrolytic capacitor is discharged (the bus voltage is lower than 36V), the machine can be maintained;
4. After the maintenance, you should carefully check that no object is left in the UPS cabinet, and the internal connection lines of the UPS are restored to the status before the maintenance. Close the rectifier switch and bypass switch, click the password lock in the upper right corner of the display interface, an unlock window pops up, and then you can enter the password (the initial password is “123456” if it is not changed by the user), as shown in Fig. 4-1. After unlocking, select the “Control” on the main menu of the monitoring display unit, click the “POWER ON”, and select the “YES”. After about 15S, the inverter of the UPS enters the standby status, and the startup is completed.
5. Ensure that all machines in the parallel system are in a bypass mode, and then close the battery switch and output switch of the machine, and disconnect its maintenance switch;
6. Set the “Manual to bypass)” of UPS-1, UPS-2, UPS-3.....UPS-N to off in sequence.
7. Check the loading and load sharing of each machine.



Note: when the parallel system is in the maintenance mode, if you unplug the parallel cable, other machines in the parallel system may be powered down; if you need to unplug the parallel cable during maintenance, you must transfer all machines in the parallel system to the maintenance

bypass mode before operation.

4.11 Reset operation after failure alarm

When the UPS is powered off due to rectifier or inverter over-temperature, overload, bus overvoltage and other reasons, you should take measures to clear the failure according to the warning information on the display screen, and then restore the UPS to the normal working status using the following reset steps.

After confirming that the failure has been cleared and there is no remote EPO signal, the user can perform the following steps:

1. After starting the display screen, the “Control” on the monitoring display interface is grayed. You can click the password lock in the upper right corner of the display interface, an unlock window pops up, and then you can enter the password (the initial password is “123456” if it is not changed by the user), as shown in Fig. 4-2. After unlocking, you should select the “Control” and “Maintain” on the main menu of the monitoring display unit, click the “CLR FAULT”, and select the “YES”. At this time, the failure clearing operation has been completed.
2. After about 10S, the UPS starts to turn on the rectifier, inverter and static switches. After startup, the UPS enters the normal working mode.



Fig. 4-11 Failure clearing confirmation interface

4.12 Autostart

When the mains supply is interrupted, the UPS supplies power to loads through the battery system, until the battery is discharged to the final discharging voltage, the UPS stops the inverter output and switches to the static bypass output. When the mains supply is recovered, the UPS automatically restarts and restores the inverter output and charge the battery. The autostart function is also suitable for the bypass mode.

4.13 Select languages

LCD menus and data are available in Chinese,English.

After starting the display screen, you can click the password lock in the upper right corner of the display interface, an unlock window pops up, and then you can enter the password (the initial password is

“123456” if it is not changed by the user), as show in Fig. 4-2. After unlocking, you can choose the “Settings” and “Common” on the main menu of the monitoring display unit, click the “Language”, and select the language to be set.

4.14 Change current date and time

After starting the display screen, you can click the password lock in the upper right corner of the display interface, an unlock window pops up, and then you can enter the password (the initial password is “123456” if it is not changed by the user), as show in Fig. 4-2. After unlocking, you can choose the “Settings” and “Common” on the main menu of the monitoring display unit, click the “Date” and “Time”, and enter the current date and time.

4.15 Control password

After starting the display screen, you can click the password lock in the upper right corner of the display interface, an unlock window pops up, and then you can enter the password (the initial password is “123456” if it is not changed by the user), as show in Fig. 4-2. After unlocking, you can choose the “Settings” and “Common” on the main menu of the monitoring display unit, click the “User password”, and enter the modified password.

Chapter Five: Operation Control Display Panel

5.1 Introduction to the monitoring panel

The operation display panel of the UPS is on the front door panel. On the operation display panel, you can control the operations of the UPS, and view all parameters, battery status, and event and warning information of the UPS. The operation display panel can be divided into two parts by functions: LCD touch screen and LED indicator.

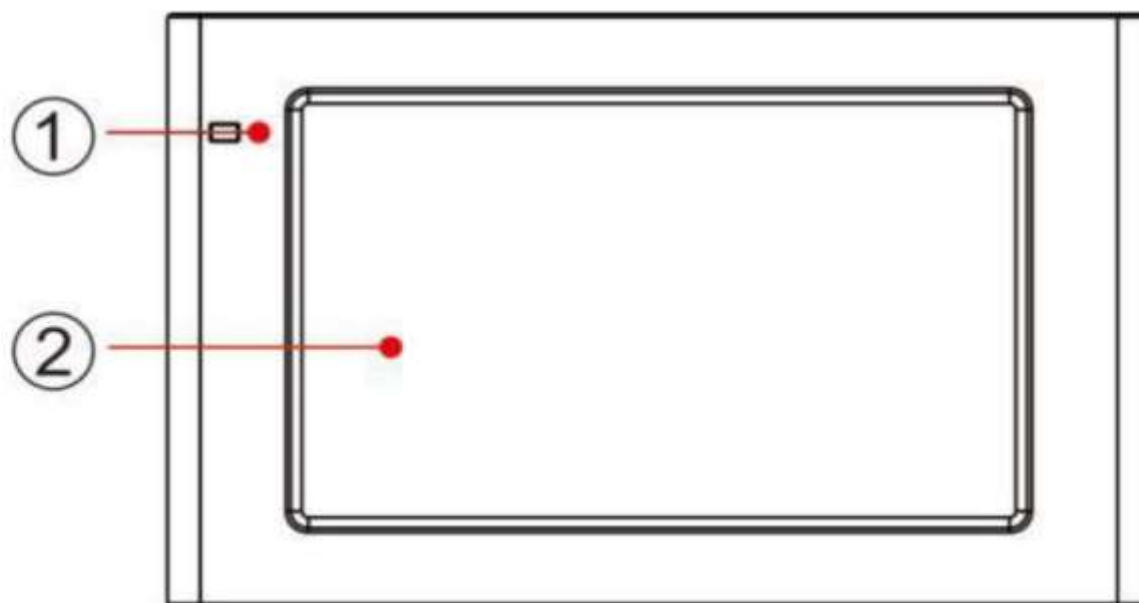

Fig. 5-1: Operation control and display panels of the UPS

① LED indicator ② LCD display touch screen

The monitoring display unit displays the running information and warning information of the UPS in real time through the LCD, and can also set and manage parameters of the UPS through the LCD. The indicator status of the monitoring display unit is shown in Table 5-1 .

Table 5-1 Table of indicator status

Indicator	Color	Status	Meaning
Indicator	Green	On	Power supply mode (mains mode, bypass mode, ECO mode, etc.)
	Red	On	UPS failure
	Red	Flashing	UPS alarm
	None	Off	Power supply mode (mains supply mode, bypass mode, ECO mode, etc.), not start or standby mode

5.1.1 Audible alarm (buzzer)

There are three kinds of audible alarms during the operation of the UPS:

Table 5-2: Description of the audible alarms of the buzzer

Brief single call alarm	This alarm sound is generated when any functional operation key is pressed
Continuous alarm call	This alarm sound is generated when the UPS is faulty
Interval alarm call	The alarm sound is generated every two seconds when the battery is being discharged
	The alarm sound is generated every one second when the battery is being discharged and is below the low voltage alarm point

5.1.2 Menu description

Select the menu icon on the LCD touch screen to view the data window data.

Fig. 5-1: Operation control and display panels of the UPS

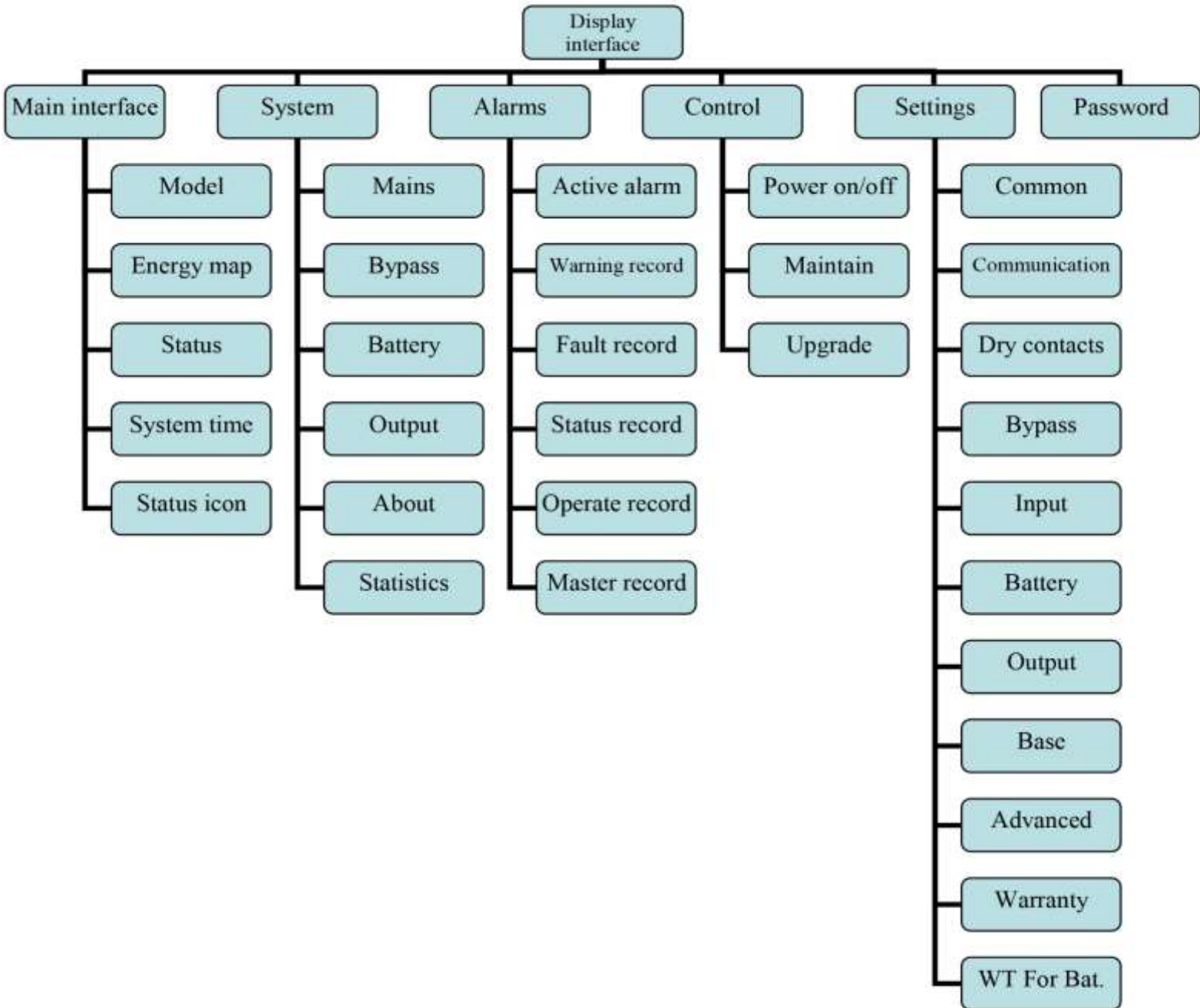









Table 5-12: UPS menu icon and UPS data window

Menu Icon	Menu Name	Menu item	Definition	
	Main interface	Return the main interface to view the energy flow chart, product model, system time and other information of the UPS		
		Mains	Voltage (V)	Input voltage
			Current (A)	Input current
			Frequency (Hz)	Input frequency
	Bypass	Voltage (V)	Bypass voltage	
		Frequency (Hz)	Bypass frequency	
		Battery	Battery voltage (V)	Battery voltage
			Battery current (A)	Battery charge/discharge current
			Battery status	Battery equalizing charge, battery floating charge, battery discharge, battery self-test
			Battery information	100AH*50 cells*1 pack
			Envir. temperature (°C)	Environmental temperature
			Next self-test	The default status is Off, and this needs to be set through the background
			Battery temperature (°C)	The battery temperature can be displayed only when the battery temperature compensation accessory is connected
			Max. cell voltage (mV)	Displayed in the lithium battery mode only
			Min. cell voltage (mV)	Displayed in the lithium battery mode only
			Max. cell temper.(°C)	Displayed in the lithium battery mode only
	Min. cell temper. (°C)	Displayed in the lithium battery mode only		
		Output	Voltage (V)	Output voltage
			Current (A)	Output current
			Frequency (Hz)	Output frequency
		Load	Load ratio (%)	Output load rate
Out PF			Power factor	
Apparent power(kVA)			Sout: apparent power	
Active power (kW)	Pout: active power			
About	UPS S/N	Display the Serial No. of products		
	Parallel ID	Display the UPS No.		
	TEL	Display the telephone number of the manufacturer		
	Manufacturer	Display the company name of the manufacturer		
	Website	Display the company website of the manufacturer		
	Model	Display the product model and system information		
	HMI version	Display the program version of the display screen		
	MSB version	The program version of the monitoring panel		
	MCB version	The program version of the main control panel		
Statistics	Bypass runtime(min)	Record the accumulated operation time of bypass		
	Inv. runtime(min)	Record the accumulated running time of inverter		
	Last discharge	Record the latest battery discharge time		
	Batt. expire time	Prompt battery over guarantee time		
	UPS expire time	Prompt UPS over warranty time		
	Active alarm	Active alarm	Display current alarm information	

	Warning record	Warning record	Record the history alarm		
	Fault record	Fault record	Record the history failure		
	Status record	Status record	Record the history status		
	Operate record	Operate record	Record the history operation		
	Master record	Master record	Read the main control history record		
	Power on/off	System on-off	Inv. on	Startup (turn on the rectifier, inverter and stasis switches)	
			Shut to bypass	Turn off the rectifier and inverter, and the UPS transfers to bypass output	
			Shutdown	Turn off the rectifier and inverter, and there is no output from the UPS	
		Manual to bypass	ON/OFF	Set "turn on manual bypass": off/on, the default status is off	
		UPS charger	ON/OFF	Set the charger on/off (only supported by some models)	
	Maintain	TEST CMD	TEST T.	Manual battery test: terminate according to the set time	
			TEST V.	Manual battery test: terminate according to the set voltage	
			TEST LOW	Manual battery test: terminate according to the set EOD voltage	
			Cancel TEST	terminate the battery test	
		Maintain	Recover factory	Recover factory	Restore factory setting of monitoring
				Mute	Turn off/on mute
				Clear record	Empty history
				Clear faults	Clear faults
				Play Logo	Play boot animation
		USB operations	Export history	Export history	Download history
				Import logo	Update boot animation
				Imp. Sys. Info.	Import new firmware
		Upgrade	Import Firmware	Import Firmware	Import new firmware
				Upgrade	Update monitoring program firmware

	Common	Language	Display languages: English,Chinese; the default language is English
		Date	Set current date
		Time	Set current time
		Date format	Set the display format of date; the default is yy/mm/dd
		Brightness	Set screen brightness
		Auto-lock	Set the time of automatic lock screen; the default is 3 minutes
		User password	Modify user password; the default password is 123456
		Uart remote control	Set remote control enable, which is off by default

	Slot1 remote control	Set remote control enable, which is off by default		
	Slot2 remote control	Set remote control enable, which is off by default		
Communication	Serial port	Protocol	Set serial communication protocol; the default protocol is MODBUS2	
		Baud rate	Set serial communication Baud rate; the default value is 9600	
		Address	Set serial communication address bit; the default value is 1	
		Parity	Set serial communication check bit; the default status is no check	
	Intelligent slot1/Intelligent slot2	Protocol	Set SNMP communication protocol; the default protocol is MEGATEC	
		Baud rate	Set SNMP communication Baud rate; the default value is 2400	
		Address	Set SNMP communication address bit; the default value is 1	
		Parity	Set SNMP communication check bit; the default status is no check	
	Network	IP address allocation	Set the IP allocation method, dynamic and static	
		IP address	Set the IP address of the static IP	
		Subnet mask	Set subnet mask	
		Gateway	Set gateway	
	BMS protocol	Battery brand	Set lithium battery brand. Currently, only conventional brands are supported	
		BMS Protocol	Set BMS protocol, default GBMS1_3	
Dry contact	Input dry contacts	Dry contact 1	Set input dry contact 1; the default status is Off	
		Dry contact 2	Set input dry contact 2; the default status is Power on	
	Output dry contacts	Dry contact 1	Set output dry contact 1; the default status is Fan Fault	
		Dry contact 2	Set output dry contact 2; the default status is Fault alarm	
		Dry contact 3	Set output dry contact 3; the default status is Power on	
		Dry contact 4	Set output dry contact 3; the default status is Bat. Low volt.	
		Dry contact 5	Set output dry contact 4; the default status is Output Overload	
		Dry contact 6	Set output dry contact 5; the default mode is Mains mode	
	Bypass	Max. ECO voltage(%)	Ranges of upper limit of ECO voltage: 5%, 10%, 15%; the default value is 10%.	
Min. ECO voltage(%)		Ranges of lower limit of ECO voltage:5%, 10%, 15%; the default value is 10%.		
Max. bypass voltage(%)		Ranges of upper limit of bypass voltage: 10%,15%,20%,25%; the default value is 20%.		
Min. bypass voltage(%)		Ranges of lower limit of bypass voltage: 10%,20%,30%,40%,50%,60%; the default value is 20%.		
Bypass Protocol		This can be set to off/on; the default status is on		
Input	Input voltage(V)	According to the rated voltage of program initialization: 220/230/240 or 100/110/115/120/127		

	Input frequency(Hz)	Rated input frequency 50Hz/60Hz can be set; the default value is 50Hz.
	REC delay Time(s)	Time of rectifier delay start, which can be set to [1,300]; the default value is 10s.
	Input current(A)	Rectifier input current limit setting, which can be set to [0.1,1.25] or [0.1,1.1]
	REC Soft Time(s)	This can be set to 5-30 s; the default time is 10 s.
Battery	Set battery Parameters	Battery cell voltage is set to 2V/12V, lead-acid battery; this is set to 3.2V, lithium battery. For details, see the battery parameter setting section.
Output	Output voltage(V)	According to the rated voltage of program initialization: 220/230/240 or 100/110/115/120/127
	Output frequency(Hz)	Rated output frequency can be set to 50Hz/60Hz; the default value is 50Hz.
	Max.lock freq.(Hz)	Upper limit of frequency tracking range can be set to [0.1,5.0]; the default value is 3.0Hz.
	Min.lock freq.(Hz)	Lower limit of frequency tracking range can be set to [0.1,5.0]; the default value is 3.0Hz.
	Output volt. adjustment(V)	Adjusted output voltage can be set to [-5,5]; the default value is 0V.
	Phase lock rate(Hz/s)	Lock phase tracking rate can be set to [0.5,2.0]; the default value is 2.0Hz/S.
	Short circuit	Output short-circuit protection can be set to “transfer to bypass” and “shut down and interrupt output”.
Basic	Single/Parallel	Set the system to be stand-alone/parallel system
	Parallel number	Set the number of UPS in the parallel system, which can be set to 1-8
	Parallel ID	Set the UPS No. in the parallel system, which can be set to 1-8
	Advanced Password	Set the advanced password
	Time Calibration	Set the time calibration mode
	Settings wizard	Set on/off, that is, whether to enter the setting boot interface after the UPS is restarted
	Set language limit	Language setting limit enable, default off
Advanced	Working mode	Set the running mode, which can be set to UPS mode, ECO mode, EPS mode, frequency conversion mode, and voltage stabilization mode
	EPO Switch	EPO action mode can be set to “transfer to bypass”/“shut down”; the default mode is “transfer to bypass”
	Height(m)	This can be set to 0-6,000 meters; the default value is 1,000 meters (if the altitude is above 3,000 meters, please consult the manufacturer)
	Gen on(V)	Generator turn-on voltage (dry contact signal action voltage); the default value is 330/550V
	Gen off(V)	Generator turn-off voltage (dry contact signal action voltage); the default value is 360/600V
	Master Test	Start debugging mode (non-professionals are not allowed to operate); the default status is off
	Manual Shutdown	Set whether “shut down and interrupt output” is displayed on the on/off interface
	Bus check (k Ω)	Set the alarm resistance of BUS to ground (only supported by some models)

	Battery check (kΩ)	Set the alarm resistance of Battery to ground (only supported by some models)	
	Fast cutting	Set whether bypass and inverter switch quickly in ECO/EPS mode, and OFF by default	
warranty	Battery warranty	Installation time	Set the installation time of the battery
		Warranty time (year)	Set the warranty period of the battery
		Expire time	Display the battery warranty time
	UPS warranty	Installation time	Set the installation time of the UPS
		Warranty time (year)	Set the warranty period of the UPS
		Expire time	Display the UPS warranty time
WT For Bat.	WATT AND TIME	Set the watt and hour parameter of lead-acid battery to calculate the battery capacity, backup time and other parameters.	

When using the lead-acid battery, the voltage is 2V/12V, and the parameters are set as follows

Battery Parameters	Battery type	Set the lead acid battery and lithium battery, the default lead acid battery		
	Battery cell volt.(V)	Battery cell voltage 2V/3.2V/12V		
	Battery capacity(Ah)	Range of battery cell capacity 7-2,000AH.		
	Battery cells	The number of battery cells (10-120kVA)	The number of battery cells (80-500kVA)	
		2V, [168,192], the default value is 180 cells	2V, [288,312], the default value is 300 cells	
		12V, [28.32], the default value is 30 cells	12V, [48.52], the default value is 50 cells	
		3.2V, [105,120], the default value is 120 cells	3.2V, [192,208], the default value is 192 cells	
	Battery string	The number of batteries, which can be set to 1-12, and the default value is 1.		
	Charger current(C)	Display different ranges of charge current rate according to the battery cell voltage; this parameter affects the charge current of batteries. Calculation of the charge current: $I = \text{charge rate} * \text{capacity} * \text{the number of batteries} / \text{the number of parallel machines}$ (the number of parallel machines, this parameter can be effective only when the common battery capacity is enabled).		
	Float volt.(V)	Battery cell voltage	Default charging rate	Range of charging rate
2V		0.10C	[0.05C,0.25C]	
3.2V		0.20C	[0.05C,1.00C]	
12V		0.10C	[0.05C,0.25C]	
Equal. volt.(V)	Battery cell voltage	Default floating charge voltage	Range of floating charge voltage	
	2V	2.25V	[2.20,2.30]	
	3.2V	3.40V	[3.30,3.70]	
	12V	13.5V	[13.20,13.80]	
Equal. volt.(V)	Battery cell voltage	Default equalizing charge voltage	Range of equalizing charge voltage	
	2V	0.10V	[0.08, 0.17]	
	3.2V	0.00V	[0.00, 0.27]	
	12V	0.60V	[0.50, 1.00]	

Battery share	Common battery, the default status is off. The common battery is not recommended for this series products.												
Self test set	Set the battery self-test mode, which can be set to off/self-test by voltage/self-test by time.												
Self-check period(d)	Set the battery self-test period, which can be set to [30, 365], and the default period is 90 days.												
Self-check time(min)	Set the battery self-test duration, [5,240] can be set, and the default is 5 minutes.												
Self-check volt.(V)	Set the end voltage of battery self-test, the end voltage point of self-test [EOD * number of battery cells, floating charge voltage * number of battery cells], and the default value of 30 batteries is 360V; The default value of 50 batteries is 600V.												
Start self-check HM	Set the time period when the self-test is started: the time period when the self-test is allowed to be started [0000, 2359] The default time period is [0000, 0500], from 00:00 to 5:00 a.m.												
Stop self-check HM	Set the time period when the self-test is ended: the time period when the self-test is allowed to be ended [0000, 2359] The default time period is [0000, 0500], from 00:00 to 5:00 a.m.												
Online check	Set the test mode of batteries. This can be set to off/reduce benchmark/auxiliary contact.												
Battery quality	This can be set to on/off, and the default status is off.												
SOH(%)	This can be set to 0-100%, and the default value is 20%.												
Battery EOD volt.(V)	Display different DOD ranges according to the battery cell voltage <table border="1"> <thead> <tr> <th>Battery cell voltage</th> <th>Default EOD</th> <th>EOD range</th> </tr> </thead> <tbody> <tr> <td>2V</td> <td>1.65V/1.67V</td> <td>[1.60,1.80]</td> </tr> <tr> <td>3.2V</td> <td>3.00V</td> <td>[2.50,3.30]</td> </tr> <tr> <td>12V</td> <td>9.90V/10.00V</td> <td>[9.60,10.80]</td> </tr> </tbody> </table>	Battery cell voltage	Default EOD	EOD range	2V	1.65V/1.67V	[1.60,1.80]	3.2V	3.00V	[2.50,3.30]	12V	9.90V/10.00V	[9.60,10.80]
Battery cell voltage	Default EOD	EOD range											
2V	1.65V/1.67V	[1.60,1.80]											
3.2V	3.00V	[2.50,3.30]											
12V	9.90V/10.00V	[9.60,10.80]											
Battery DOD volt.(V)	Display different DOD ranges according to the battery cell voltage; this parameter indicates the added value to the EOD: DOD = EOD + added value <table border="1"> <thead> <tr> <th>Battery cell voltage</th> <th>Default DOD</th> <th>DOD range</th> </tr> </thead> <tbody> <tr> <td>2V</td> <td>0.17V</td> <td>[0.08,0.17]</td> </tr> <tr> <td>3.2V</td> <td>0.10V</td> <td>[0.05,0.40]</td> </tr> <tr> <td>12V</td> <td>1.00V</td> <td>[0.50,1.00]</td> </tr> </tbody> </table>	Battery cell voltage	Default DOD	DOD range	2V	0.17V	[0.08,0.17]	3.2V	0.10V	[0.05,0.40]	12V	1.00V	[0.50,1.00]
Battery cell voltage	Default DOD	DOD range											
2V	0.17V	[0.08,0.17]											
3.2V	0.10V	[0.05,0.40]											
12V	1.00V	[0.50,1.00]											
Charger one time(h)	The constant current charging time can be set. Conditions for the end of the first stage charging (the following conditions and/or relationships): 1. The time reaches the set point. 2. The charging voltage reaches the value of the equalizing charge voltage. This can be set to [0,100], and the default value is 100H.												
Charger two time(h)	The constant voltage charging time can be set. Conditions for the end of the second stage charging: the time reaches the set point. This can be set to [0.24], and the default value is 0H.												
Temp. ratio(mV/°C-cell)	Battery temperature compensation parameter, which can be set to -1 to -8mV/°C, and the default value is -3mV/°C												
BMS switch	Display the backup time and remaining capacity of the battery on the battery parameter interface, and the default status is off.												

Choose the 3.2V (lithium battery) cell interface

Battery Parameters	Battery type	Set the lead acid battery and lithium battery, the default lead acid battery
	Battery cell volt.(V)	Battery cell voltage 2V/3.2V/12V
	Battery capacity(Ah)	Range of battery cell capacity 7-2,000AH.

Battery cells	The number of battery cells (10-120kVA)	The number of battery cells (80-500kVA)	
	2V, [168,192], the default value is 180 cells	2V, [288,312], the default value is 300 cells	
	12V, [28.32], the default value is 30 cells	12V, [48.52], the default value is 50 cells	
	3.2V, [105,120], the default value is 120 cells	3.2V, [192,208], the default value is 192 cells	
Battery string	The number of batteries, which can be set to 1-12, and the default value is 1.		
Charger current(C)	Display different ranges of charge current rate according to the battery cell voltage; this parameter affects the charge current of batteries. Calculation of the charge current: $I = \text{charge rate} * \text{capacity} * \text{the number of batteries} / \text{the number of parallel machines}$ (the number of parallel machines, this parameter can be effective only when the common battery capacity is enabled).		
	Battery cell voltage	Default charging rate	Range of charging rate
	2V	0.10C	[0.05C,0.25C]
	3.2V	0.20C	[0.05C,1.00C]
Float volt.(V)	Display different ranges of floating charge voltage according to the battery cell voltage		
	Battery cell voltage	Default floating charge voltage	Range of floating charge voltage
	2V	2.25V	[2.20,2.30]
	3.2V	3.40V	[3.30,3.70]
Equal. volt.(V)	Display different ranges of equalizing charge voltage according to the battery cell voltage; this parameter indicates the added value to the floating charge voltage: $\text{equalizing charge voltage} = \text{floating charge voltage} + \text{added value}$		
	Battery cell voltage	Default equalizing charge voltage	Range of equalizing charge voltage
	2V	0.10V	[0.08, 0.17]
	3.2V	0.00V	[0.00, 0.27]
Battery share	Common battery, the default status is off. The common battery is not recommended for this series products.		
	Self test set	Set the battery self-test mode, which can be set to off/self-test by voltage/self-test by time.	
	Self-check period(d)	Set the battery self-test period, which can be set to [30, 365], and the default period is 90 days.	
	Self-check time(min)	Set the battery self-test duration, [5,240] can be set, and the default is 5 minutes.	
Self-check volt.(V)	Set the end voltage of battery self-test, the end voltage point of self-test [EOD * number of battery cells, floating charge voltage * number of battery cells], and the default value of 30 batteries is 360V; The default value of 50 batteries is 600V.		
Start self-check HM	Set the time period when the self-test is started: the time period when the self-test is allowed to be started [0000, 2359] The default time period is [0000, 0500], from 00:00 to 5:00 a.m.		
Stop self-check HM	Set the time period when the self-test is ended: the time period when the self-test is allowed to be ended [0000, 2359] The default time period is [0000, 0500], from 00:00 to 5:00 a.m.		

Online check	Set the test mode of batteries. This can be set to off/reduce benchmark/auxiliary contact.		
Battery quality	This can be set to on/off, and the default status is off.		
SOH(%)	This can be set to 0-100%, and the default value is 20%.		
Battery EOD volt.(V)	Display different DOD ranges according to the battery cell voltage		
	Battery cell voltage	Default EOD	EOD range
	2V	1.65V/1.67V	[1.60,1.80]
	3.2V	3.00V	[2.50,3.30]
Battery DOD volt.(V)	Display different DOD ranges according to the battery cell voltage; this parameter indicates the added value to the EOD: DOD = EOD + added value		
	Battery cell voltage	Default DOD	DOD range
	2V	0.17V	[0.08,0.17]
	3.2V	0.10V	[0.05,0.40]
12V	1.00V	[0.50,1.00]	
BMS Alarm En	Whether the UPS generates alarms when the BMS communication is not connected it; it is on by default.		
Cell high volt. (V)	Battery cell high voltage, which can be set to 3.20-5.00V, and the default value is 3.65V		
Cell Low volt. (V)	Battery cell low voltage, which can be set to 2.00-3.20V, and the default value is 2.50V		
Group pressure alarm (V)	Battery high voltage alarm, which can be set to 3.20-5.00V, and the default value is 3.80V		
Group pressure protect (V)	Battery high voltage protection, which can be set to 3.20-5.00V, and the default value is 3.90V		
Over charge cuur. (C)	Battery overcharged current, which can be set to 0.05-1.00C, and the default value is 1.00C.		
Over discharge cuur. (C)	Battery overcharged current, which can be set to 0.05-5.00C, and the default value is 4.00C.		

Notes:

For the UPS with the DC input voltage of 360VDC, the standard configuration of the lithium battery is 16 (the number of cells in each pack) × 7 (pack) consisting of 112 cells, and the floating charge voltage is 380.4V. For the UPS with the DC input voltage of 600VDC, the standard configuration of the lithium battery is 16 (the number of cells in each pack) × 12 (pack) consisting of 192 cells, and the floating charge voltage is 652.80V. When the lithium battery is inconsistent with the standard battery, please consult the manufacturer of the UPS.

5.1.3 Current information recording window

Click the “Alarms” “Active alarm” on the main interface to view events. This window records events about the current running mode of the UPS, and does not record the recovered status.

For the complete history, please review the history information in the “Alarms”-“Master record”.

5.2 List of events displayed on LCD panel

Table 5-13: List of the displayed events

UPS events	Explanation
The battery equalizing charging occurs	Battery status (equalizing charging)
The battery floating charging occurs	Battery status (floating charging)
The battery discharging occurs	Battery status (discharging)
The battery is being self-tested	Battery status (being self-tested)
The rectifier normal working occurs	The rectifier is working normally
The battery does not occur	The battery is not connected
The battery connection occurs	The battery has been connected
The output air switch closure occurs	The UPS output switch is closed
The output air switch disconnection occurs	The UPS output switch is disconnected
The bypass power supply occurs	The bypass is normal
The bypass power supply failure occurs	The bypass is abnormal
The inverter soft start occurs	The inverter is soft started
The inverter normal working occurs	The inverter is working normally
The inverter power supply failure occurs	The inverter is shut down or faulty
The inverter supplying no power occurs	The inverter does not supply power
The inverter supplying power occurs	The inverter is supplying power
The maintenance bypass air switch closure occurs	The maintenance bypass switch is closed
The maintenance bypass air switch disconnection occurs	The maintenance bypass switch is disconnected
The emergency shutdown occurs	Emergency shutdown: received the external emergency shutdown order
The inverter static switch closure occurs	The inverter static switch is closed
The inverter static switch disconnection occurs	The inverter static switch is disconnected
The effective manual bypass occurs	Manual bypass effective
The manual bypass release occurs	The manual bypass is ineffective
The mains fault occurs	Mains supply failure
The mains fault disappears	The mains supply is normal
The rectifier fault occurs	Rectifier failure
The rectifier fault disappears	The rectifier is normal
The inverter fault occurs	The inverter is abnormal
The inverter fault disappears	The inverter is normal
The bypass fault occurs	Bypass failure
The bypass fault disappears	The bypass is normal
The low A-phase output voltage occurs	A-phase output voltage is low
The high A-phase output voltage occurs	A-phase output voltage is high
The abnormal A-phase output voltage disappears	The A-phase output voltage is normal
The low B-phase output voltage occurs	B-phase output voltage is low
The high B-phase output voltage occur	B-phase output voltage is high
The abnormal B-phase output voltage disappears	The B-phase output voltage is normal
The low C-phase output voltage occurs	C-phase output voltage is low
The high C-phase output voltage occurs	C-phase output voltage is high
The abnormal C-phase output voltage disappears	The C-phase output voltage is normal
The abnormal mains voltage occurs	The mains voltage is abnormal
The abnormal mains voltage disappears	The mains voltage is normal
The abnormal mains frequency occurs	The mains frequency is abnormal
The abnormal mains frequency disappears	The mains frequency is normal
The reverse main circuit input phase occurs	The main circuit input phase sequence is reversed
The reverse main circuit input phase disappears	The main circuit input phase sequence is normal
The input soft start failure occurs	The rectifier is abnormal
The input soft start failure disappears	The input soft start is normal
The bus overvoltage occurs	The DC bus voltage is abnormal
The bus overvoltage disappears	The bus voltage is normal
The battery low voltage occurs	The battery voltage is low
The battery low voltage disappears	The battery returns to normal

The reverse bypass phase sequence connection occurs	The bypass voltage phase sequence is reverse Under normal conditions, B-phase lags by 120 degrees behind A-phase, and C-phase lags by 120 degrees behind B-phase. Check whether UPS bypass input phase sequence is correct.
The reverse bypass phase sequence connection disappears	The bypass phase sequence is correct
The abnormal bypass voltage occurs	The bypass voltage is abnormal
The abnormal bypass voltage disappears	The bypass voltage is normal
The bypass thyristor failure occurs	The bypass static switch is abnormal
The bypass thyristor failure disappears	The bypass static switch is normal
The abnormal bypass frequency occurs	The bypass frequency is abnormal
The abnormal bypass frequency disappears	The bypass frequency is normal
Local overload timeout occurs	The UPS is overload and exceeds the allowed overload time. Note 1: the maximum load phase first displays overload timeout; Note 2: when the load exceeds the rated value, it should display "local output overload"; Note 3: when the allowed overload time is exceeded, the inverter static switch is disconnected, and the load is switched to be powered by bypass; when the inverter is in a standby status, after 10 s, if the bypass is powered down, the load is switched to be powered by inverter and such switch can only occur five times within an hour. Note 4: the load rate of the maximum load phase is reduced to less than 90%, and the system is switched to inverter power supply mode. View the load percentage displayed on the LCD panel to confirm whether the alarm is real. Note 4: after the overload timeout machine automatically shuts down, you must clear the fault first before you restart the machine.
The local overload timeout disappears	The local output is not overloaded
The limit of the number of switches within an hour occurs	The number of overload switches exceeds the set point within the first hour, making the load in the bypass power supply status. The UPS can be automatically recovered and switched to the inverter power supply status within an hour
The limit of the number of switches within an hour disappears	The limit of the number of switches within an hour is cleared
The fan fault occurs	The fan is not connected or faulty
The fan fault disappears	The fan is normal
The fuse fault occurs	Fuse damaged
The fuse fault disappears	The fuse is normal
The inverter over-temperature occurs	The inverter temperature is too high
The inverter over-temperature disappears	The inverter temperature is normal
The inverter IGBT over-current occurs	The inverter IGBT current value is out of the range
The inverter IGBT over-current disappears	The inverter IGBT current is normal
The local output overload occurs	When the load exceeds 105% of the rated value, this alarm will be generated. When the overload status is cleared, the alarm is automatically recovered. 1. View the load percentage displayed on the LCD panel to determine which phase is overloaded, so as to determine whether the alarm is real. 2. If the alarm is real, please measure the actual output current to determine the correctness of the displayed value. Disconnect non-critical loads In the parallel system, if loads are severely unbalanced, this alarm will also be generated.
Local output overload disappears	Local output is not overloaded
Inverter thyristor fault occurs	Inverter static switch is abnormal
Inverter thyristor fault disappears	Inverter static switch is normal
Output short circuit occurs	Output short circuit
Output short circuit disappears	Output short circuit is cleared

Chapter Six: Daily Management and Maintenance

6.1 Machine room management

The machine room management includes the environmental safety management of the machine room and the device management.

1. Basic tasks of the environmental safety management are to ensure that elements such as the environmental temperature, relative humidity, cleanliness, static interference, noises and strong current electromagnetic interference meet requirements, ensure the stable performance, reliable operation and safe production of the power supply devices, and ensure the normal power supply of the powered devices.
2. Basic requirements for device management are to ensure that the mechanical properties of the device are intact, the electrical properties of the device meet the standard requirements, the device is running stably and reliably, and the technical data and original records of the device is complete.

6.2 Maintenance guideline

The proper maintenance (including preventive maintenance and remedial maintenance) is the key to optimal UPS operation, and can ensure a longer life of the device. The preventive measurement includes procedures that are often performed, and these procedures are used to prevent system faults and to achieve the maximum operational efficiency. The remedial maintenance includes finding and effectively repair the system faults.

6.3 Safety precautions

To safely and successfully maintain the system, you must follow the safety precautions, use the necessary tools and test equipment, and have qualified maintenance personnel, and always keep in mind the following safe operation rules:

1. Always keep in mind that there is dangerous voltage in the UPS, even when the UPS system is not running.
2. Ensure that the operation and maintenance personnel of the UPS are familiar with the device and content in this manual.
3. Do not wear gold or silver jewelry, such as rings and watches, when operating the UPS.
4. Do not take safe operation procedures for granted. If you have any question, please consult those familiar with the device.

5. Always keep in mind that there is dangerous voltage in the UPS, and check the UPS with a voltmeter to ensure the power supply is off and the UPS is in a safe state before maintenance and adjustment.

6.4 Preventive periodic maintenance

The preventive maintenance steps are described below. These steps will improve the efficiency and reliability of the UPS system.

1. Keep the environment clean and avoid dust or chemical pollution to the UPS.
2. Keep the area around the UPS system clean and ensure the unobstructed access to the device.
3. The input and output cable terminals should be checked once every six months to carefully examine and measure whether the contact is good.
4. Regularly check the working status of the cooling fans to prevent the obstruction of the outlet. If damaged, it should be replaced.
5. Regularly check the battery voltage and the working status of the UPS.

6.5 Use and maintenance of batteries

6.5.1 Charging and discharging of batteries

Batteries are an important component to ensure the uninterruptible power supply of the UPS. Batteries are mounted to the battery shunt of the UPS system. When the mains supply works normally, the batteries are floating charged or equalizing charged by the power system; when the mains supply is cut off, the batteries supply power to the user device by the inverter.

6.5.2 Selection of batteries

1. The battery capacity is selected according to the current required by the powered device and the expected battery discharge time in the power supply system. For example, the discharge current of the battery is 100A in the power supply system, and we hope that the continuous power supply time of the battery during the AC power failure period is 2h, then the battery capacity required by the system = discharge current of the battery × continuous power supply time during the AC power failure = 200Ah. After the theoretical battery capacity is obtained, a surplus is added to it to obtain the actual battery capacity. The selected battery capacity is higher rather than lower, but it should not be higher than 20% of the capacity required by the powered device.
2. Batteries with different capacities should not be used in series, and batteries with different voltages should not be used in parallel.
3. Batteries with different capacities should not be used in series (the internal resistance of batteries are different, and the capacities cannot be saturated at the same time due to the different current during charging, which may lead to overcharged and undercharged batteries; batteries may discharge to each

other during discharging).

6.5.3 Precautions for the use and maintenance of batteries

1. When multiple batteries are connected in parallel, the total capacity is the sum of the capacity of each battery.
2. The service temperature of the battery is 0-40°C, and the life of the battery is inversely proportional to the temperature. Therefore, the heat dissipation should be fully considered in applications where the battery temperature tends to rise, so as to prevent the rise of the battery temperature (when the battery temperature rises, the polar plate is more corroded by sulfuric acid, thus shortening the battery life); if possible, air conditioning can be installed in the machine room to prolong the service life of batteries.
3. After the power supply system is installed, the batteries that are used for the first or have not been used for a long time must be charged before use; the battery will lose its capacity slowly due to the long-time self-discharge during the storage, and will not reach the corresponding performance if not charged.
4. The connection parts of the battery, connection wires for the fastener status, and other components should be regularly checked and fastened to avoid the accidents.
5. Batteries must be replaced by qualified professional maintenance personnel.

6.6 Software Download & Installation (Only for the model with communication port)

Please follow steps below to download and install monitoring software :

1. Go to the website <https://www.idbkmonitor.com>
2. Click UPSSmartView software icon and then choose your required OS to download the software
3. Follow the on-screen instructions to install the software